

L I M I T E D   L I A B I L I T Y   C O M P A N Y

**VOSTOK** *neftegaz*

SCIENTIFIC-TECHNICAL FIRM

**MORE THAN 13 YEARS**  
**OF PROVIDING PROFESSIONAL AND INNOVATIVE SOLUTIONS**  
**FOR OIL AND GAS INDUSTRY**

**TECHNOLOGIES • PRODUCTION • SERVICE**

UFA 2016



General manager of STF "VOSTOKneftegaz" LLC,  
Professor of "Gas and oil products transportation  
and storage" department of Ufa State Petroleum  
Technological University,  
Doctor of Engineering Sciences,  
Acad. Gubkin award laureate,  
Honored inventor of Bashkortostan republic.

**MUGALLIMOV FANZIL**

The primary goal of the company is to assist our Client in settling the matters of operating the pipeline systems, through fulfilling our potential and providing innovative end-to-end solutions.

Our goal is achieved owing to the following:

- Persistent engineering, upgrading and production of high-quality pigging devices, monitoring devices for locating the pigs, devices for short-time control of the pumping and technological parameters of transported product;
- Providing the pipeline integrity management services.

This becomes possible, because we are the team of associates holding the same views, which combine professionalism, experience, energy and responsibility. Highly-qualified researchers, engineers, designer and production engineers, as well as electronics engineers and programmers will efficiently and constructively solve complex issues within the set time limits.

The information, provided in the catalogue, presents patented state-of-art and well-recognized devices, as well as peculiar technologies considering energy performance of pipeline maintenance.

High quality of developed standard-technical documents and technology regulations guarantees industrial and environmental safety.

Our strategy – is ensuring the safety and efficiency of Clients' O&G pipeline operation.

With kind regards, F. Mugallimov

# TABLE OF CONTENTS

<b>GEOGRAPHICAL RANGE OF CLIENTS</b>	<b>2</b>
<b>KEY AREAS OF ACTIVITY</b>	<b>3</b>
<b>PRODUCTION</b>	
CLEANING PIGS	4
TRANSMITTER-INTEGRATED CLEANING PIGS	10
DEVICES FOR TRACKING AND MONITORING THE LOCATION OF CLEANING AND SMART PIGS IN PIPELINES	13
DEVICES FOR MONITORING THE CHARACTERISTICS OF OPERATING PROCEDURES	20
COMPONENTS OF CLEANING PIGS	24
FIELD OF APPLICATION OF CLEANING PIGS	26
<b>TECHNOLOGIES</b>	
TRACKING THE LOCATION OF PIGS STUCK IN THE PIPELINE	28
VISUAL PIPELINE INSPECTION	28
TECHNOLOGY OF IN-LINE INSPECTION	29
TECHNOLOGY OF PIGGING LENGTHILY UNCLEANNED PIPELINES	33
TECHNOLOGY OF SUPERVISING THE SUBMERGED CROSSING	34
TECHNOLOGY OF PIGGING, WITH PERIODIC REMOVAL OF DE-POSITS USING THE PLUNGER	36
TECHNOLOGY OF PIGGING AND GAUGING THE PIPELINE UPON ITS LAYING	37
<b>SERVICE</b>	<b>38</b>
<b>GOST-R CERTIFICATES</b>	<b>42</b>
<b>LICENSES AND CERTIFICATES OF APPROVAL</b>	<b>42</b>
<b>PATENTS ON OUR ENGINEERING</b>	<b>43</b>
<b>DIPLOMAS AND CERTIFICATES</b>	<b>44</b>
<b>AWARDS</b>	



**IMPORTANT:**  
THE TITLES IN BRACKETS INDICATE FORMERLY USED  
(THROUGH TO 2015) ITEM NAMES.

## GEOGRAPHICAL RANGE OF CLIENTS

**In Russia:** Saint-Petersburg, Moscow, Bryansk, Syzran, Samara, Stavropol, Krasnodar, Neftekumsk, Buzuluk, So-rochinsk, Buguruslan, Almeteyevsk, Yelabuga, Naberezhnye Chelny, Nurlat, Izhevsk, Votkinsk, Kambarka, Sarapul, Igra, Neftekamsk, Tuymazy, Ishimbay, Yanaul, Chelyabinsk, Yekate-rinburg, Beloyarsk, Omsk, Pechora, Usinsk, Tarko-Sale, Nyagan, Noyabrsk, Megion, Raduzhny, Surgut, Pyt-Yakh, Uray, Vysoky, Kogalym, Nefteyugansk, Nizhnevartovsk, Tomsk, Ir-kutsk, Khabarovsk, Yuzhno-Sakhalinsk, Purpe, Petropavlovsk-Kamchatsky, Gubkinsky, Novy Urengoy.

**In Kazakhstan:** Atyrau, Aktobe, Kyzylorda, Shymkent, Al-maty, Astana, Kandyagash.



**Research institutes:** "KaspiyMunayGaz", "Academy of Sci-ences of Bashkortostan republic", "SamaraNIPIneft", "YuganskNIPIneft", "Bashgeoproekt", "BashNIPIneft", "Yugraneftegaz-proekt".

**O&G companies:** "Gazpromneft", "LUKOIL", "Rosneft", "Bash-neft", "Tatneft", "Megionneft-egaz", "Russneft", "RITEK", "TNK BP", "Sur-gutneftegaz", "Kazakhturkmunay", "Aktobemunay-gaz", "KuatAmlonMu-nay", "Slavneft-Megionneftegaz", "Slavneft-Krasnoyarskneftegaz".

**Construction companies:** "Vostokmontazhstroy", "Uralnefte-gazstroy", "Lengazpets-stroy", "Dalspetsstroy", "Voronezhtruboprovod-stroy".



## KEY AREAS OF ACTIVITY

### 1. Production of equipment for pigging the pipeline interior and monitoring devices of varied functionality.

- 1.1. Production of cleaning pigs designed for pigging the interior of pipelines of  $\varnothing=89-1420$  mm.
- 1.2. Production of devices for searching and tracking cleaning pigs in a pipeline, devices for measuring the characteristics of pumping and transported product, devices for surveying the wells.

### 2. Pigging and engineering diagnostics of pipelines.

- 1.1. Pigging of the pipeline interior (incl. the lengthily un-cleaned ones).
- 1.2. Discharge of product from pipelines withdrawn from service, with monitoring the pigs' location.
- 1.2. Visual pipeline inspection.
- 1.3. Surveying the pipeline using in-line smart pigs (gauging, profile logging and flaw detection).

### 3. Examination of industrial safety of hazardous production facilities.

- 3.1. Examination of industrial safety of pipelines, based on results of visual and in-line inspection with calculations of strength and residual life.
- 3.2. Justification of industrial safety of hazardous production facilities, with risk assessment.

### 4. Development of standard-technical documents, technology regulations and O&G loss norms.

- 4.1. Development of standard and technical documents for pipeline systems.
- 4.2. Development of technology regulations on operation of the pipelines and oil skimming and processing facilities (O&G processing facilities, booster stations, sewage pumping stations, preliminary water removal units, pipeline commissioning stations, etc).
- 4.3. Development of loss norms for oil and associated gas, as well as utilizing O&G for needs of oil and gas production enterprises.

### 5. R&D aimed at designing the means of in-line pigging and inspection of pipelines, as well as ensuring the safety while carrying out emergency and repair operations.

### 6. Instructing the specialists on technologies of pipeline pigging and in-line inspection.

ALL OF THE PRODUCTION IS GOST-R CERTIFIED AND AUTHORIZED FOR APPLICATION BY "ROSTECHNADZOR".



## CLEANING PIGS

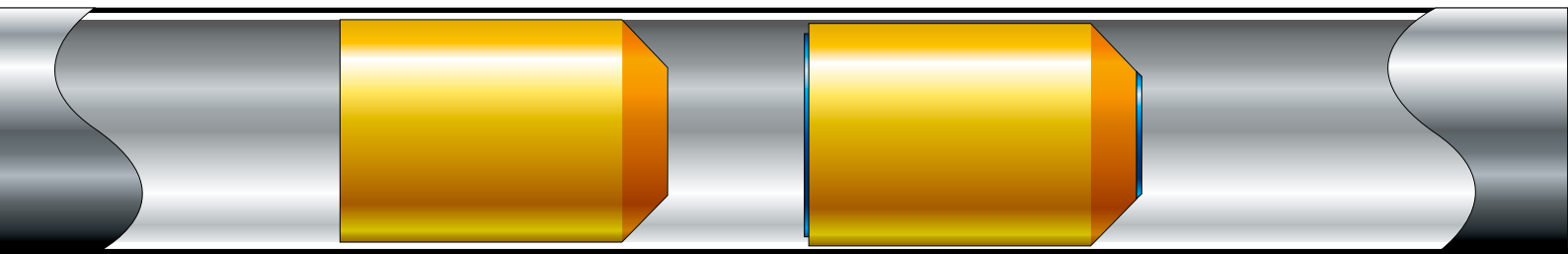

VOSTOK-PM

VOSTOK-PU

### RF PATENTS

№ 2296015

№ 2296632

№ 64536

### CERTIFICATE OF CONFORMITY

№ РОСС RU.MH10.H00068

### FOAM PIGS

Cleaning pig "VOSTOK-PM" is a molded pliable foam pig de-signed for pipelines of  $\varnothing=89-530$  mm, made of foam with densi-ty= $30 \text{ kg/m}^3$  and higher, lined on the edge with (polyurethane) foam with density= $70 \text{ kg/m}^3$  and higher.

Cleaning pig "VOSTOK-PU" is a molded reinforced foam pig designed for pipelines of  $\varnothing=89-1420$  mm, lined along the surface with (polyurethane) foam with density= $70 \text{ kg/m}^3$  and higher.

Cleaning pig "VOSTOK-PB" is molded foam "Puncheon"-type pig, made of 2 alternate materials (foam and oil-petrol-resistant sheet rubber or polyurethane).

Foam pigs are suitable for:

- cleaning the pipeline interior from mild deposits, removal of condensate and water;
- pigging the pipelines with alternating inside run-in clearance;
- inspecting the pipeline piggability;
- conducting the works on purging, testing and abandonment of transfer/upstream pipelines under construction or in operation;
- preliminary disposal of liquid.

Foam cleaning pigs are capable of passing the pipeline con-figuration discrepancies of up to 45% of the outside diameter and 90-degree branch connections with swing radius of 1,5 DN and higher.

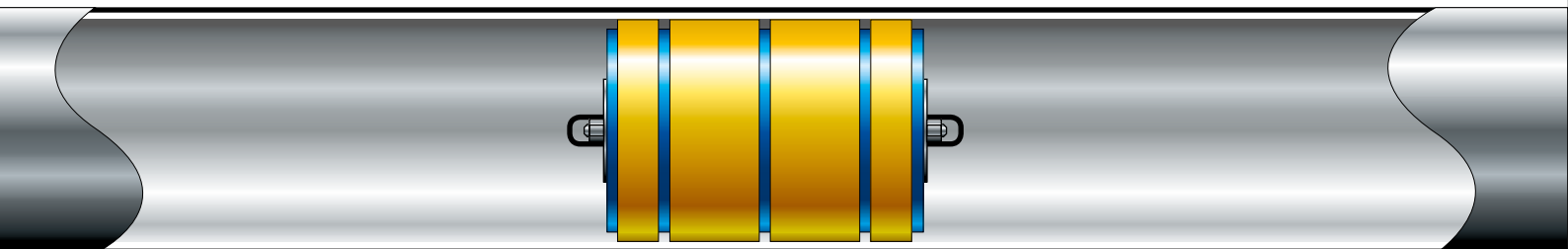

VOSTOK-PB

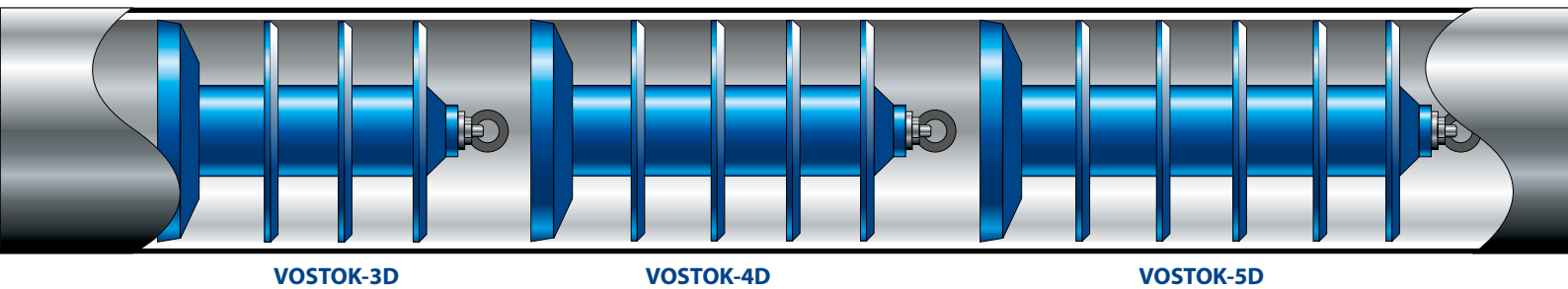

**MONOBLOCK FOAM PIGS**

Monoblock pigs "VOSTOK-XD-XXX" are designed for pig-ging the pipelines of  $\varnothing=89-325$  mm in the course of operation or construction (water pumping for hydrotesting, water or product displacement, final inspection of the product, separation of petro-leum products, purging the pipeline).

The pig is molded with fixed (nonremovable) cleaning detail parts, available in 3 options (at the Client's discretion): 3 foam cleaning disks in "VOSTOK-3D-XXX", 4 disks in "VOSTOK-4D-XXX" or 5 disks in "VOSTOK-5D-XXX", plus 1 foam cup.

There is no metal frame.

Minimum swing radius for "VOSTOK-3D-XXX" and "VOSTOK-4D-XXX" is 1,5 DN with bend angle of 90 degrees, for "VOSTOK-5d-XXX" – 3 DN with bend angle of 90 degrees.

"VOSTOK-XD-XXX" pig may be supplied with a slot for in-stalling the transmitter, available for  $\varnothing=159-325$  mm.

The pig may be supplied with a transmitter (the pig locating device), available for  $\varnothing=159$  mm,  $\varnothing=219$  mm,  $\varnothing=273$  mm,  $\varnothing=325$  mm. In that case the pigs will be marked as "VOSTOK-3DT-XXX", "VOSTOK-4DT-XXX" and "VOSTOK-5DT-XXX".

**RF PATENT**  
№ 127330

**CERTIFICATE OF CONFORMITY**  
№ POCC RU.MH10.H00067



**VOSTOK-PP**

**VOSTOK-PR**

**VOSTOK-SHP**

**FOAM SPHERE "VOSTOK-SHP", MONOBLOCK CLEANING PIGS "VOSTOK-PR" (RUBBER) AND "VOSTOK-PP" (POLYURETHANE)**

Monoblock cleaning pigs, designed for cleaning the up-stream pipeline interior from asphalt, resin, paraffin and other deposits, as well as displacement of product and foreign objects from the interior of pipelines of  $\varnothing=89-377$  mm, are capable of passing 90-degree branch connections with swing radius of 1,5 DN and higher.

Cleaning pigs "VOSTOK-PR" made of oil-petrol-resistant rubber are suitable for pipelines of  $\varnothing=89-273$  mm, pigs "VOSTOK-PP" made of polyurethane are suitable for pipelines of  $\varnothing=89-377$  mm.

Cleaning pigs are manufactured with no metal frame.

Polyurethane spheres "VOSTOK-SHP" (with density= $1,1-1,2 \text{ g/sm}^3$ ) are designed for pigging and displacement of the product from upstream pipelines, rebound hardness:

- 45-55 units extrasoft (ES) – up to 30% diameter deformation;
- 55-65 units soft (S) – up to 30% diameter deformation;
- 5-75 units medium-hard (MH) – up to 20% deformation;
- > 75 units hard (H) – up to 15% deformation.

Outside diameters of spheres are: 55 mm, 64 mm, 70 mm, 75 mm, 81 mm, 95 mm, 98 mm, 100 mm, 102 mm, 106 mm, 123 mm, 128 mm, 134 mm, 138 mm, 142 mm, 147 mm, 155 mm, 175 mm, 200 mm, 207 mm и 253 mm.

**RF PATENT**  
№ 127331

**CERTIFICATE OF CONFORMITY**  
№ POCC RU.MH10.H00067

# CLEANING PIGS

**CERTIFICATE  
OF CONFORMITY**  
№ POCC RU.MH10.H00069

Cleaning pigs "VOSTOK-D6", "VOSTOK-MD" and "VOSTOK-M4" are de-signed for cleaning pipeline interior from asphalt, resin, paraffin deposits, foreign objects, displacement and separation of various pumping products, inspecting the pipeline run-in clearance (when installing the gauging unit).

Cleaning pigs stand out for simplicity and reliability of their design, their abil-ity to pass the pipeline configuration discrepancies of up to 35% of the outside diameter and 90-degree branch connections with swing radius of 1,5 DN and higher, as well as straight unbarred tees.

## CLEANING DISK PIGS "VOSTOK-D6", CUP-DISK PIGS "VOSTOK-MD" AND CUP PIGS "VOSTOK-M4" FOR PIPE-LINES OF Ø=89-273 MM

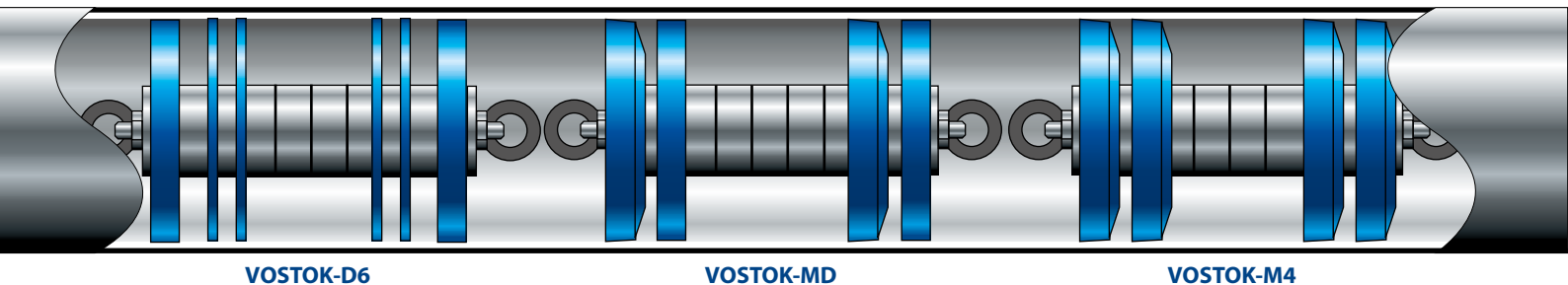

VOSTOK-D6

VOSTOK-MD

VOSTOK-M4

## CLEANING DISK PIGS "VOSTOK-D6", CUP-DISK PIGS "VOSTOK-MD" AND CUP PIGS "VOSTOK-M4" FOR PIPE-LINES OF Ø=325-1420 MM

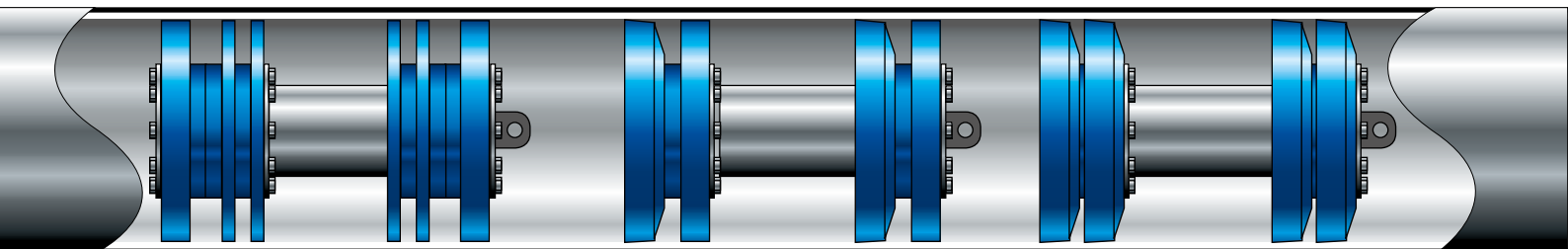

VOSTOK-D6

VOSTOK-MD

VOSTOK-M4

Polyurethane or rubber disks or cups of various density and shape are used as cleaning detail parts.

There is an option of additional installation of attachments (brushing, mag-netic or gauging units), necessary for cleaning the pipeline interior from scale, in-crustant asphalt and resin deposits, incrustation and electrodes, as well as for pipeline gauging.

Cleaning transmitter-integrated pigs (equipped with electromagnetic signal-transmitting device) or pigs, installed on transmitter's body, are marked with "T" (transmitter), e.g. "VOSTOK-MDT".



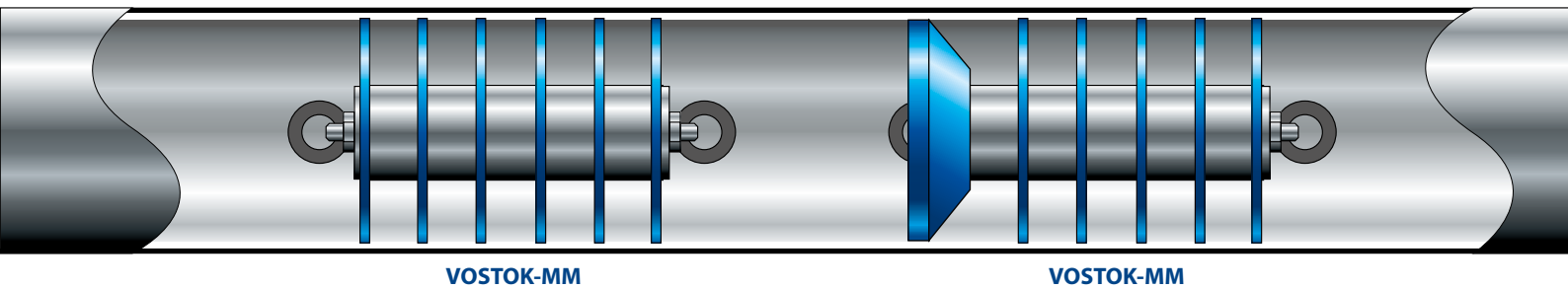

#### MULTICUP CLEANING PIGS “VOSTOK-MM”

Cleaning pigs of “VOSTOK-MM” type are designed for pipelines of  $\varnothing=89-530$  mm. “VOSTOK-MM” is capable of passing the pipeline configuration discrepancies of up to 40% of the outside diameter and 90-degree branch connections with swing radius of 1,5 DN and higher, as well as straight unbarred tees.

Polyurethane or rubber disks or cups of various density and shape are used as cleaning detail parts. In contrast to monoblock pigs, the detail parts are subject to replacement, as the latter wear out.

There is an option of additional installation of attachments (brushing, gauging or magnetic units), necessary for cleaning the pipeline interior from incrustation, scale, incrustant asphalt and resin deposits, as well as for pipeline gauging.

**CERTIFICATE  
OF CONFORMITY**  
№ POCC RU.MH10.H00069

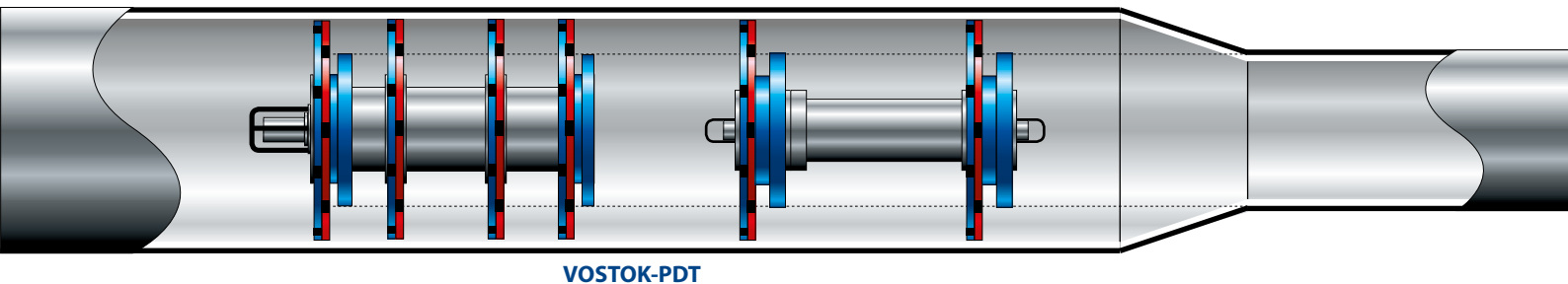

#### CLEANING PIGS WITH ALTERNATING DIAMETER “VOSTOK-PD”

“VOSTOK-PD” are designed for pigging the pipelines of variable diameter=89–530 mm and stand out for their ability to pass and clean the pipeline segments with diameter variation not exceeding 110 mm and 90-degree branch connections with swing radius of 1,5 DN and higher, as well as straight unbarred tees.

Double (tightly fixed) rubber or polyurethane disks with segment cuts are used as cleaning detail parts. Moreover, segment cuts of one disk are overlapped by the petals of another closely mounted disk. As the pipeline diameter decreases during the progression of a cleaning pig, the disk petals fold, which allows passing the pipeline segment with smaller diameter, and in case of diameter increase the petals revert to the original state. Disks with diameter equal to the inside diameter of the smaller-diameter pipeline are used as additional backing disks.

**RF PATENT**  
№ 125104

**CERTIFICATE  
OF CONFORMITY**  
№ POCC RU.MH10.H00069

## CLEANING PIGS

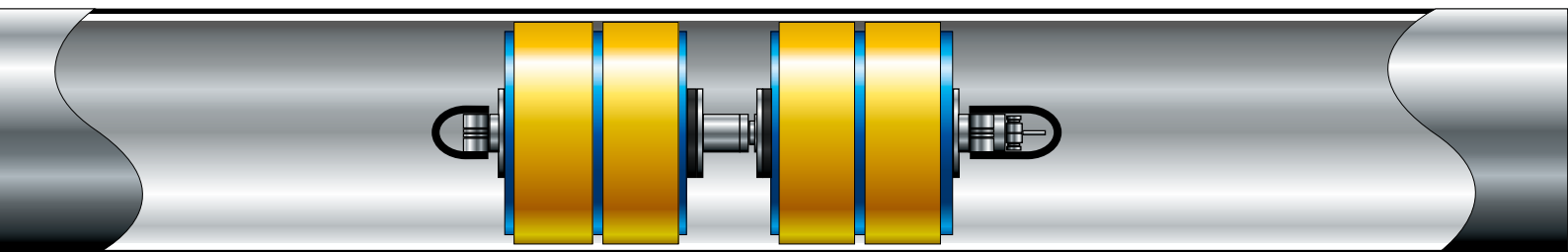

**VOSTOK-KSK**

**RF PATENTS**

№ 2277983

№ 2324551

**CERTIFICATE OF CONFORMITY**

№ POCC RU.MH10.H00070

**COMBINED CLEANING PIGS WITH CROSS-COUNTRY POWER "VOSTOK-KSK"**

Combined cleaning pigs are designed for cleaning the pipeline interior from asphalt, resin and paraffin deposits, well as displacement of product and foreign objects. They are used for pipelines of  $\varnothing=89-530$  mm. The cleaning pigs stand out for their ability to pass the pipeline configuration discrepancies of up to 45% of the outside diameter and 90-degree branch connections with swing radius of up to 1,5 DN, as well as straight unbarred tees.

"VOSTOK-KSK" cleaning pigs are notable for their frame made of flexible material (wire cable), with oil-petrol-resistant rubber or polyurethane cleaning disks and polyurethane (foam) insertion pieces installed onto it. The frame is able to bend along the axis while progressing through curves and narrow segments of the pipe-line, ensuring unchecked advance of the pig.

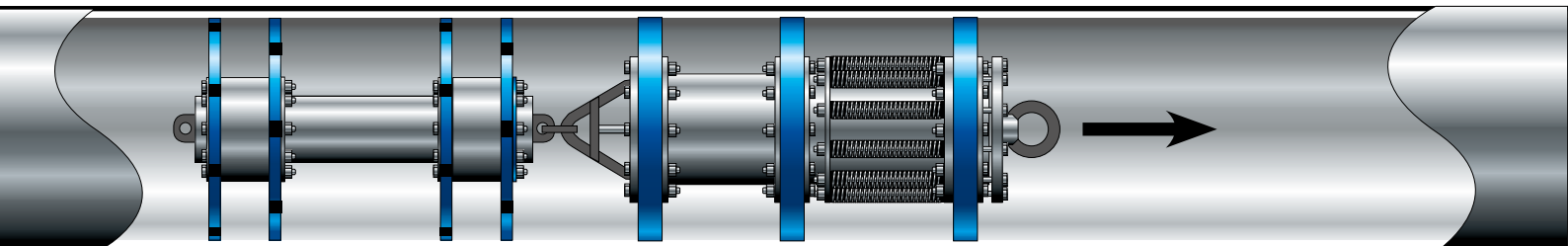

**VOSTOK-KL**

**VOSTOK-KLT**

**RF PATENTS**

№ 2324550

№ 2110729

**CERTIFICATE OF CONFORMITY**

№ POCC RU.MH10.H00069

**CLEANING PIGS "VOSTOK-KL" ("TORNADO") WITH PRODUCT CROSS-OVER**

VOSTOK-KLT" cleaning pigs are designed for cleaning the pipeline interior from asphalt, resin and paraffin deposits, for crude oil lines of  $\varnothing=219-530$  mm. "VOSTOK-KL" stands out for its ability to overflow the pumped product through itself (up to 20%) in the event of increase in pressure differential "in front of" and "at the back of" the cleaning pig, in case of excessive accumulation of deposits ahead of the pig or its stoppage. When this occurs, the pig's valve opens (front flange shifts forward), the pumped product washes out, fractures and carries over from the front of the pig.

"VOSTOK-KLT" pigs of "Tornado" type stand out for their ability to pass the pipeline configuration discrepancies of up to 20% of the outside diameter and 90-degree branch connections with swing radius of up to 1,5 DN, as well as straight unbarred tees. Polyurethane or rubber disks or cups of various density are used as cleaning detail parts.

"VOSTOK-KLT" pigs of "Tornado" type may be used in set with "VOSTOK-T" pig. Using the joint, transmitter "VOSTOK-T" with cups of matching diameter is attached to "VOSTOK-KLT". In case of pig stoppage in a pipeline there is an opportunity to identify its location following the electromagnetic signals of the transmitter.

## CLEANING PIGS

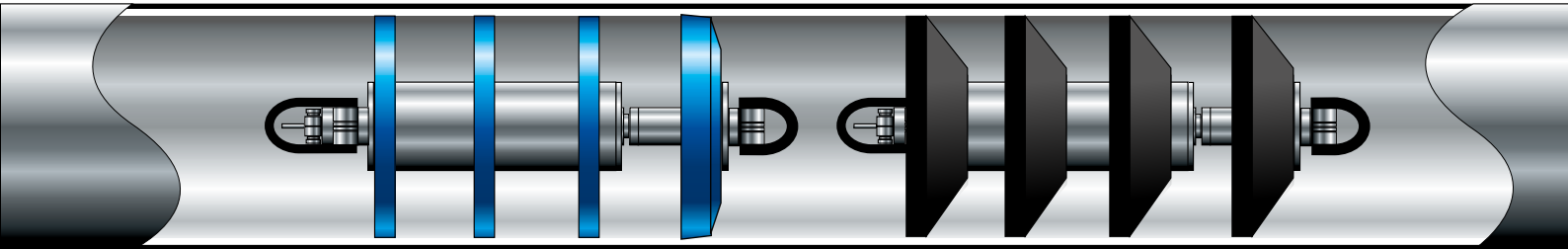

**VOSTOK-KS**

### CLEANING PIGS WITH CROSS-COUNTRY POWER "VOSTOK-KS"

Cleaning pigs with cross-country power cleaning pigs are designed for cleaning the pipelines of  $\varnothing=89-530$  mm from asphalt, resin and par-affin deposits. The pigs are able to bend along its axis while progressing through curves and turns of branch connections, pass the pipeline configuration discrepancies of up to 40% of the outside diameter and 90-degree branch connections with swing radius of up to 1,5 DN, as well as straight unbarred tees.

Polyurethane and rubber disks and cups are used as cleaning de-tail parts. The 1st cone cup is the leading one, 3 following disks or cups of the cleaning pig have cylindrical holes for leveling the pressure of the pumped product between them.

"VOSTOK-KS" pig is notable for its frame made of flexible material (wire cable), with cleaning disks and cups installed onto it.

**RF PATENTS**  
№ 2277983

**CERTIFICATE  
OF CONFORMITY**  
№ POCC RU.MH10.H00070

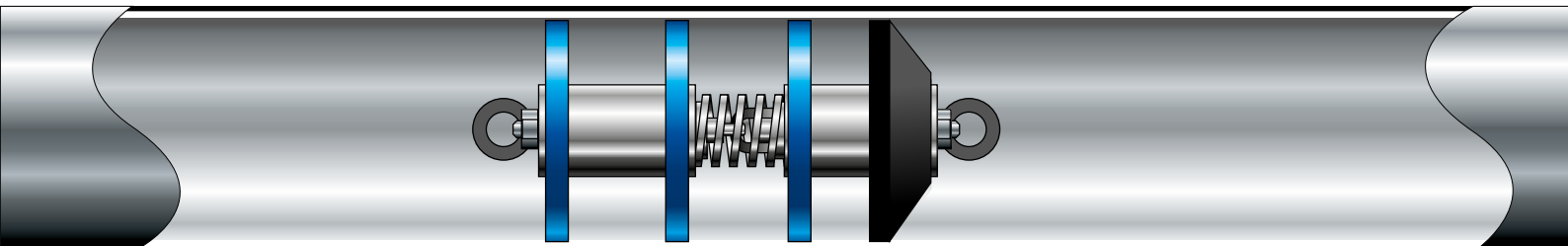

**VOSTOK-PC**

### CLEANING PIGS WITH COIL SPRING "VOSTOK-PS"

"VOSTOK-PS" pigs feature 2 sections, jointly interconnected with a coil spring, which allows the cleaning pig twist and revert to the original state while progressing through branch connections and pipeline turns of  $\varnothing=89-530$  mm.

**CERTIFICATE  
OF CONFORMITY**  
№ POCC RU.MH10.H00070

# TRANSMITTER-INTEGRATED CLEANING PIGS

**RF PATENT**  
№ 2110729

**CERTIFICATE  
OF CONFORMITY**  
№ POCC RU.MH10.H00069

“VOSTOK-D6T”, “VOSTOK-D4T” and “VOSTOK-MDT” type cleaning pigs are designed for pigging and inspecting gauging (in-specting the run-in clearance) the pipelines of  $\varnothing=114$  mm, 159 mm, 168 mm, 219 mm, 273 mm, 325 mm. The transmitter is the actual body of the cleaning pig for pipelines of  $\varnothing=114-325$  mm. For pipe-lines of  $\varnothing=325-1420$  mm the transmitter is integrated into the body of the cleaning pig, which allows to control the pig's progression along the pipeline, track and identify its location from the ground surface in case of the pig's stoppage. Cleaning pigs pass 90-degree branch connections with swing radius of 1,5 DN and higher, as well as straight unbarred tees.

## CLEANING DISK PIGS “VOSTOK-D6T”, CUP-DISK PIGS “VOSTOK-MDT” AND CUP PIGS “VOSTOK-M4T” FOR PIPELINES OF $\varnothing=114$ MM

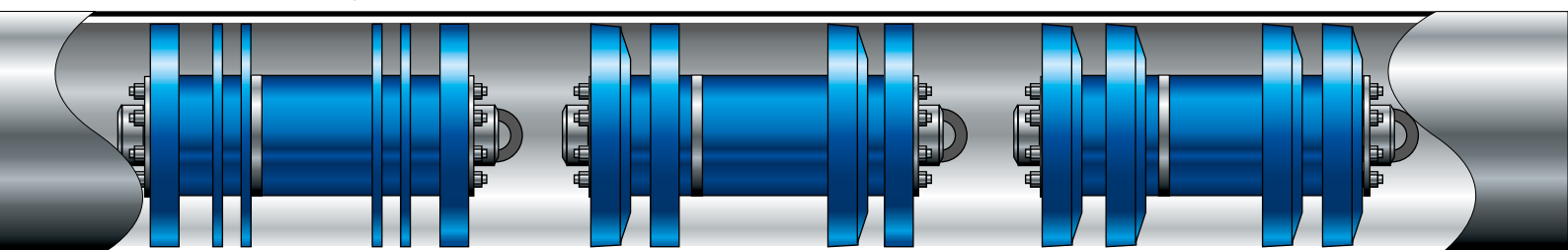

VOSTOK-D6T

VOSTOK-MDT

VOSTOK-M4T

## CLEANING DISK PIGS “VOSTOK-D6T”, CUP-DISK PIGS “VOSTOK-MDT” AND CUP PIGS “VOSTOK-M4T” FOR PIPELINES OF $\varnothing=159-168$ MM

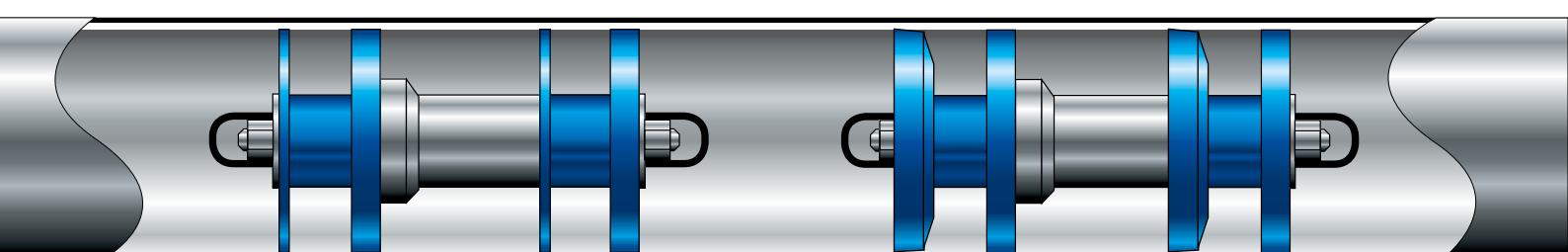

VOSTOK-D4T

VOSTOK-MDT

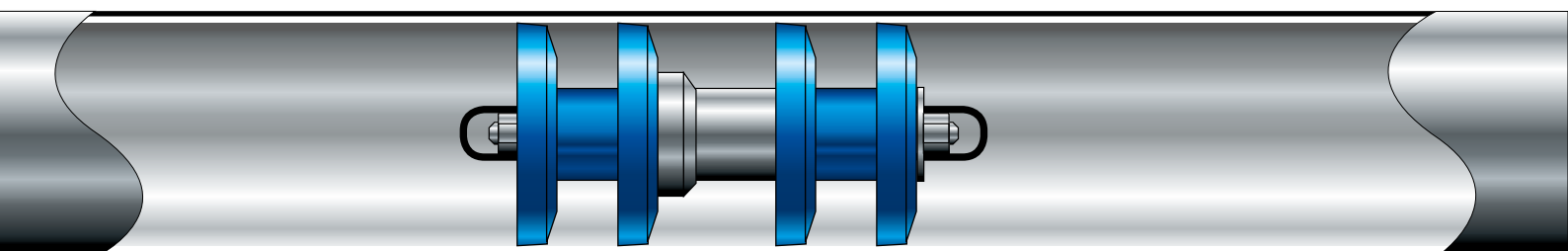

VOSTOK-M4T

# TRANSMITTER-INTEGRATED CLEANING PIGS

CLEANING DISK PIGS "VOSTOK-D6T", CUP-DISK PIGS "VOSTOK-MDT" AND CUP PIGS "VOSTOK-M4T"  
FOR PIPELINES OF  $\varnothing=219-325$  MM

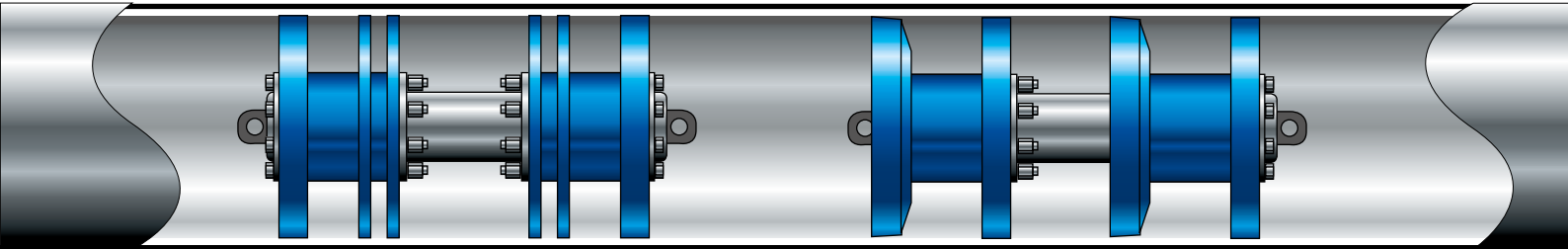

VOSTOK-D6T

VOSTOK-MDT

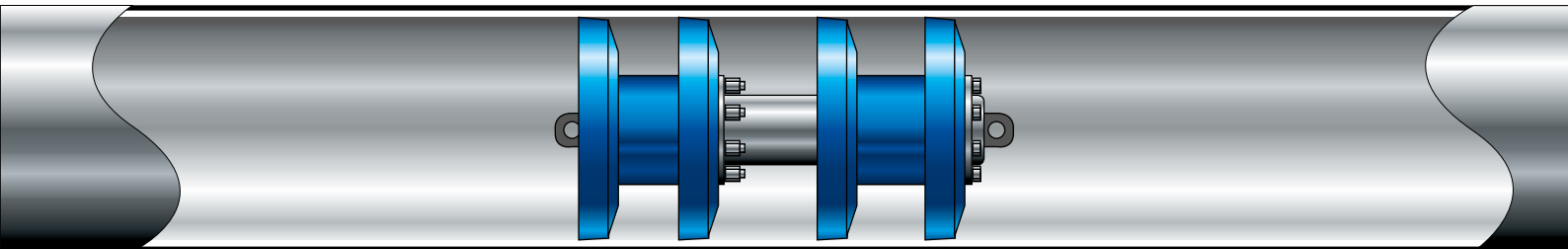

VOSTOK-M4T

CLEANING DISK PIGS "VOSTOK-D6T", CUP-DISK PIGS "VOSTOK-MDT" AND CUP PIGS "VOSTOK-M4T"  
FOR PIPELINES OF  $\varnothing=325-1420$  MM

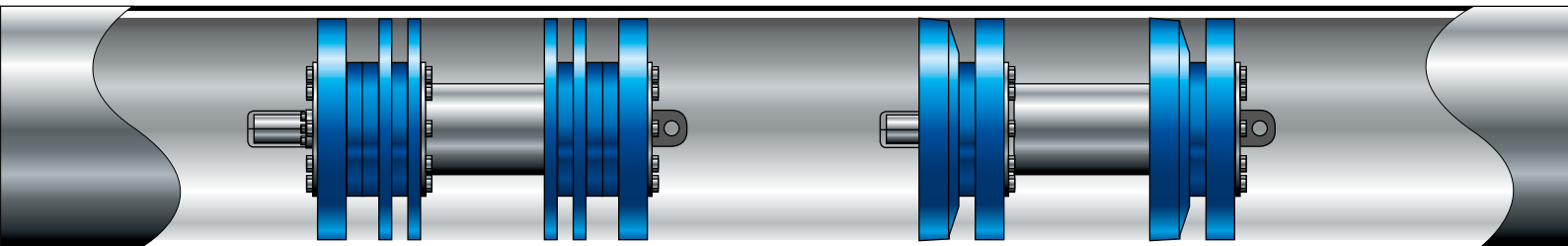

VOSTOK-D6T

VOSTOK-MDT

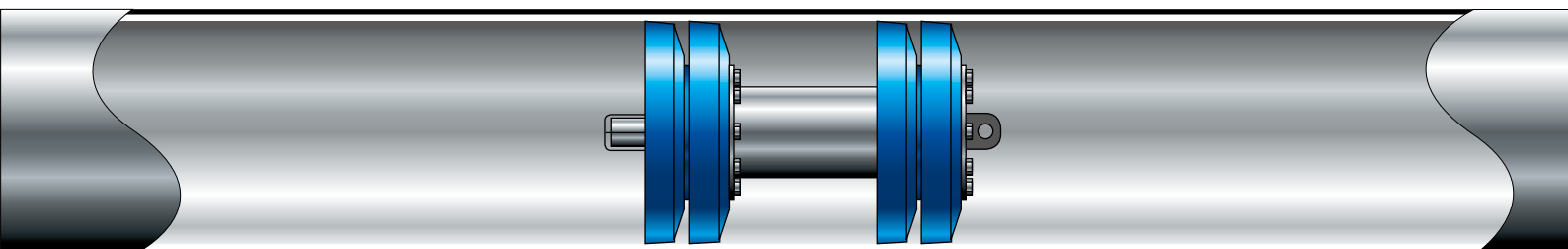

VOSTOK-M4T



# TRANSMITTER-INTEGRATED CLEANING PIGS

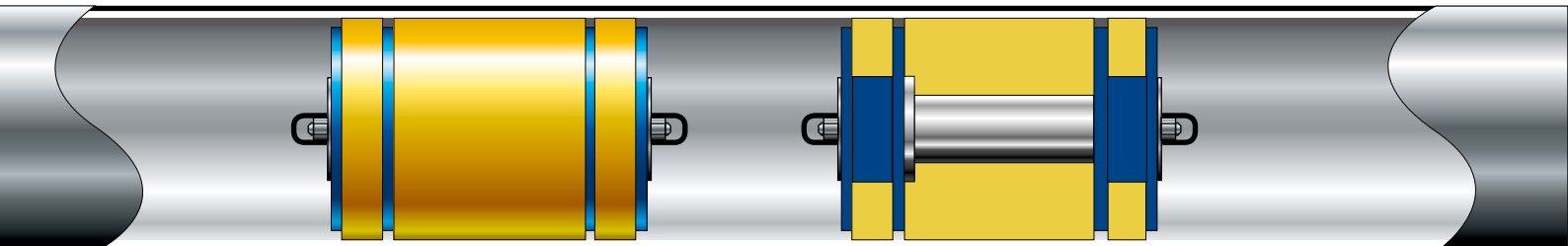

VOSTOK-PBT

**RF PATENT**  
№ 2110729  
№ 2369453

**CERTIFICATES  
OF CONFORMITY**  
№ РОСС RU.АЯ36.H24968  
№ РОСС RU.MH10.H00068

## FOAM CLEANING PIG “VOSTOK-PBT”

Foam cleaning pig “VOSTOK-PBT” of “Puncheon” type with a transmitter is designed for pigging the pipelines of  $\varnothing=159-720$  mm, including lengthily uncleaned pipelines. “VOSTOK-PBT” pig is capable of passing the pipeline configuration discrepancies of up to 45% of the outside diameter and 90-degree branch connections with swing radius of 1,5 DN. It allows to control the pig’s progression along the pipeline, track and identify its location from the ground surface in case of the pig’s stoppage.

“VOSTOK-PBT” features the transmitter-integrated cleaning pig with disks of diameter equal to the one of the pipeline and foam insertion pieces, as well as the portable receiver in a stow-age box.



## DEVICES FOR TRACKING AND MONITORING THE LOCATION OF CLEANING AND SMART PIGS IN PIPELINES



**RF PATENT**  
№ 2137977

**CERTIFICATE  
OF CONFORMITY**  
№ РОСС RU.MH10.H00044



### ACOUSTIC MOLE "VOSTOK-AL" (SENSOR)

Acoustic mole "VOSTOK-AL" is designed for monitoring the location of cleaning and smart pigs in random spots of the pipeline corridor from the ground surface, as well as in gate valves, plug valves, plungers and open segments of the pipeline. The device features an electronic control unit, a headset, a geophone with extension cable, a conical dowel, a magnetic holder, a power cord (compatible with car's lighter socket), a charging unit and a stowage box.

#### KEY TECHNICAL PARAMETERS

1. Device weight in stowage box – 2,2 kg.
2. Critical dimensions – 390x365x80 mm.
3. Period of continuous operation using internal power source – min 50 hours.
4. Maximum distance of device detection – 2500 m (depending on device's design and method of sensitive element installation).
5. Extension cable length – 8–10 m.
6. Device's motion speed is not limited.

The geophone is installed in place of monitoring true-vertically, digging the conical dowel in the ground above the pipeline or using the magnetic holder to place the device onto the valves or the pipeline itself. The device's progression is monitored aurally using the headset and/or visually using the LED indicator. Device's motion speed is not limited.

## DEVICES FOR TRACKING AND MONITORING THE LOCATION OF CLEANING AND SMART PIGS IN PIPELINES

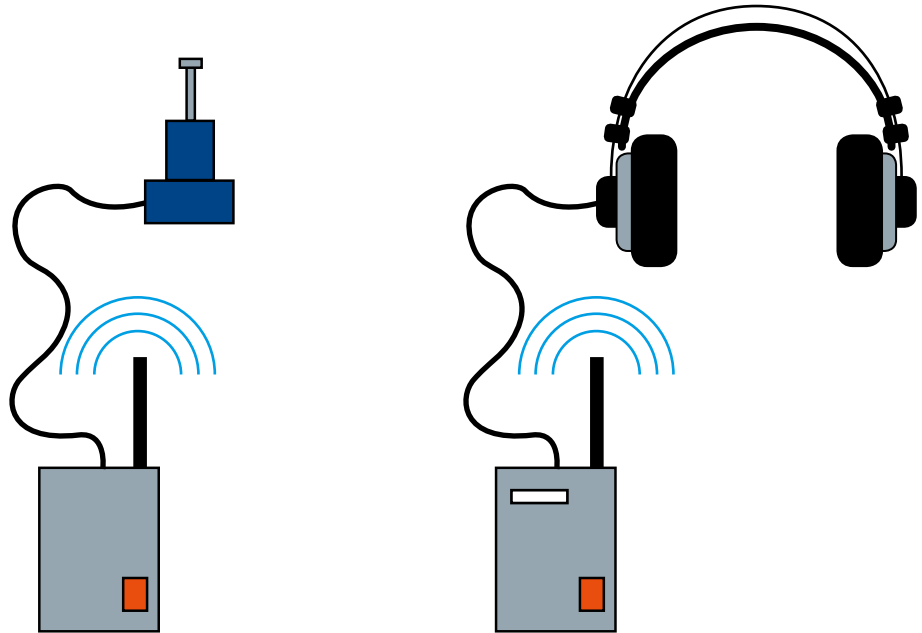

### ACOUSTIC RADAR “VOSTOK-ALR” FOR TRACKING AND MONITORING THE LOCATION OF IN-LINE CLEANING AND SMART PIGS IN PIPELINES

Acoustic radar “VOSTOK-ALR” is designed for monitoring the running and location of cleaning and smart pigs in random spots of the pipeline corridor from the ground surface, as well as in gate valves, plug valves, plungers and open segments of the pipeline via wireless link between the sensitive element and the receiver.

#### DEVICE COMPONENTS

The device set features the following: radio-signal transmitter with an aerial and a sensitive element, magnetic holder of the element, metal dowel, radio-signal receiver and aerial, a headset and a stowage box.

#### KEY TECHNICAL PARAMETERS

1. Set weight in stowage box – max 3 kg.
2. Power source – lithium cells (3,6 V).
3. Average period of continuous operation using power source – min 5 days.
4. Range of transmitter signals delivered to the receiver in moderate visibility – 700 m.
5. Maximum distance between the check point and the device available for monitoring its running – 500–2500 m (depending on device’s design and method of sensitive element installation).

6. Device’s motion speed is not limited.

The device’s progression is monitored aurally using the headset and/or visually using the LED indicator on the receiver.

The device’s sensitive element is installed at the check point onto the valves or the pipeline itself using the magnetic holder or in the ground above the pipeline by digging the dowel.

In case of poor weather conditions, the radar allows to monitor the running and location of in-line pigs remotely from the car no farther than 700 m from the pipeline (from the sensitive element’s installation spot).

## DEVICES FOR TRACKING AND MONITORING THE LOCATION OF CLEANING AND SMART PIGS IN PIPELINES



**RF PATENT**  
№ 2110729

**CERTIFICATE  
OF CONFORMITY**  
POCC RU.MH10.H000045.



### LOW-FREQUENCY MOLE "VOSTOK-NL" (POISK-MP-L)

Low-frequency mole "VOSTOK-NL" is designed for receiving electromagnetic signals, generated by transmitters of "VOSTOK-T" series, which allow identifying the location of cleaning pigs. Mole's method of procedure is based on receiving and decoding electromagnetic waves of infra-low frequency 13, 22 Hz and a specific encoded signal with "SEMIGOR" frequency, delivered as signals in "signal-pause" format or in continuous-wave mode from transmitters installed onto the cleaning pigs. This gives an opportunity to monitor the cleaning pig's running and identify the location in case of its stoppage in the pipeline within the accuracy of +0.5 m.

**The device is designed for use together with any modifications of "VOSTOK-T" transmitter series, any modifications of pig transmitters manufactured by "TRANSNEFT-DIASKAN", any modifications of low-frequency transmitters manufactured by "APRODIT", any modifications of transmitters manufactured by "SEMIGORYE", any modifications of transmitters manufactured by "ROSEN Group" and other transmitters, generating signals of frequency 22 Hz.**

Low-frequency mole "VOSTOK-NL" is portable. It is a self-contained unit in a tough case, supplied with an aerial and a patch cord.

# DEVICES FOR TRACKING AND MONITORING THE LOCATION OF CLEANING AND SMART PIGS IN PIPELINES

## Parameters of the low-frequency mole “VOSTOK-NL”

Parameter description	Value
Over-the-air distance, which allows the low-frequency mole's aerial to steadily receive the transmitter's signal (given the aligning arrangement of the mole's aerials and the transmitter, as well as interference elimination)	Up to 25 m
Running time at ambient temperature of -20 – +40°C	70 hours
Power source	4 lithium cells (1,5 V)
Operating temperature range	-20 – +60°C
Operating temperature range for extreme conditions	-40 – +60°C
Net weight with the aerial, max	5 kg
Critical dimensions:	
– low-frequency mole (width x height x length)	75x220x200 mm
– aerial (diameter x length)	50x310 mm
Accuracy of cleaning pig's location identification	+ 0,5 m
Ability to receive the transmitter's signal with hanging aerial (during the device's progression through the corridor)	Yes
The transmitter's signal is reflected on:	– LCD display; – point indicator
Control of the mole's operation (setting the operation mode, scanning the stored data) is conducted:	From the panel keyboard
Embedded global positioning system (GPS-receiver)	Yes
Ability to store the data regarding the day and time of recording the transmitter signal from the pipeline and its type	Yes
Protocol type for data output via USB to the computer	– day and time of recording the transmitter signal; – signal type (13, 22 Hz and “SEMIGOR”); – signal transmission time (1:1, 1:2, 1:3, 1:6, continuous)

## TRANSMITTER «VOSTOK-T»

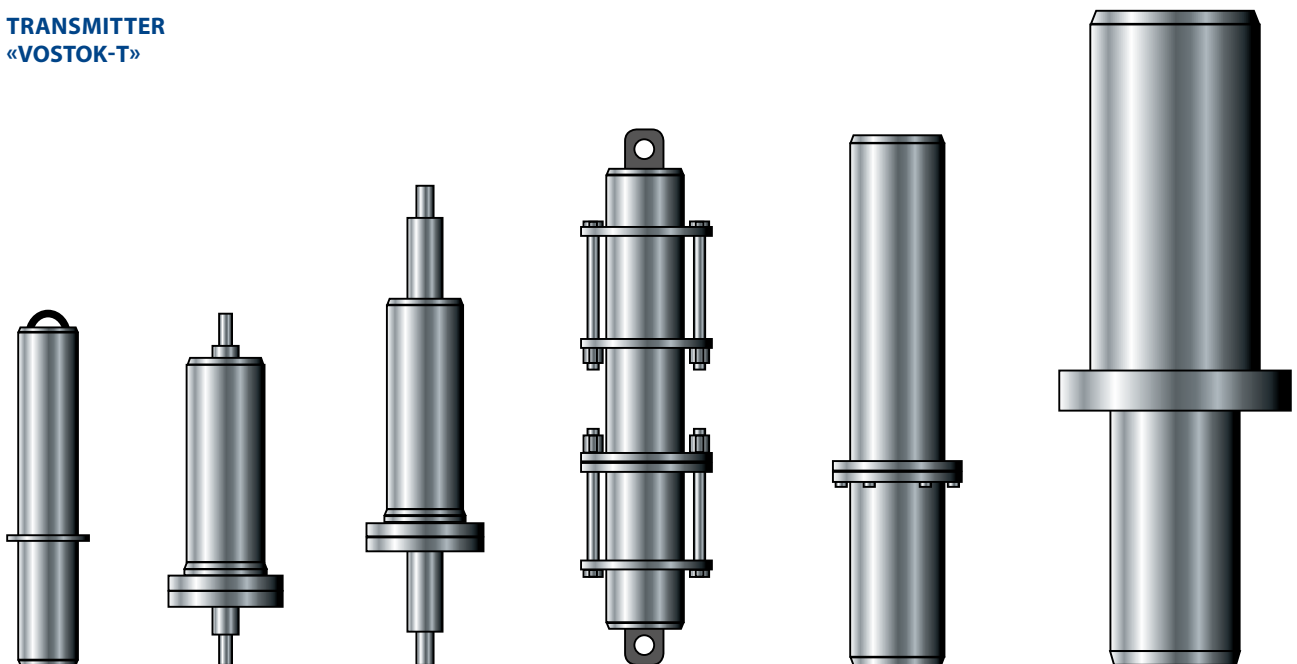



## DEVICES FOR TRACKING AND MONITORING THE LOCATION OF CLEANING AND SMART PIGS IN PIPELINES

“VOSTOK-T” transmitters are designed for generating electromagnetic signals, which give an opportunity to identify the location of cleaning pigs using the low-frequency mole (receiver) “VOSTOK-NL”. Transmitters’ method of procedure is based on transmission of electromagnetic waves of infra-low frequency 13, 22 Hz and an encoded signal with “SEMIGOR” frequency, delivered as signals in “signal-pause” format or in continuous-wave mode.

Transmitters allow tracking and identifying the location of a pig in case of its stoppage in the pipeline. They are installed onto the cleaning pigs, which are further launched into pipelines.

**Transmitters are able to be used together with low-frequency moles “VOSTOK-NL”, low-frequency mole manufactured by “TRANSNEFT-DIASKAN”, any modifications of low-frequency moles manufactured by “APRODIT”, receiver manufactured by “SEMIGORYE”, low-frequency mole manufactured by “ROSEN Group” and other low-frequency moles, operating with signals of frequency 22 Hz.**

### TRANSMITTER “VOSTOK-T40” (FIGURE “40” CORRESPONDS TO BODY DIAMETER OF 41 MM)

For pipelines of  $\varnothing=114$  mm and 159 (168) mm there are cleaning pigs “VOSTOK-D4T”, “VOSTOK-D6T”, “VOSTOK-M4T” and “VOSTOK-MDT”, based on modification of “VOSTOK-T40” transmitter with flange.

For pipelines of  $\varnothing=159$  (168) mm, 219 mm, 273 mm and 325 mm transmitters of “VOSTOK-T40B” modification are also installed onto monoblock cleaning pigs “VOSTOK-3DT”, “VOSTOK-4DT” and “VOSTOK-5DT”.

### TRANSMITTER “VOSTOK-T60” (FIGURE “60” CORRESPONDS TO BODY DIAMETER OF 62 MM)

For pipelines of  $\varnothing=159$  (168) mm there are cleaning pigs “VOSTOK-D4T”, “VOSTOK-D6T”, “VOSTOK-M4T” and “VOSTOK-MDT”, based on modification of “VOSTOK-T60” transmitter with flange.

For pipelines of  $\varnothing=219$  mm, 273 mm and 325 mm transmitters of “VOSTOK-T60B” modification are also installed onto monoblock cleaning pigs “VOSTOK-3DT”, “VOSTOK-4DT” and “VOSTOK-5DT”.

### TRANSMITTER “VOSTOK-T80” (FIGURE “80” CORRESPONDS TO BODY DIAMETER OF 80 MM)

For pipelines of  $\varnothing=219$  mm, 273 mm and 325 mm there are cleaning pigs “VOSTOK-D4T”, “VOSTOK-D6T”, “VOSTOK-M4T” and “VOSTOK-MDT”, based on modification of “VOSTOK-T80” transmitter with flange.

For pipelines of  $\varnothing=325$  mm, 377 mm, 426 mm, 530 mm, 720 mm, 820 mm, 1020 mm, 1220 mm и 1420 mm transmitters of “VOSTOK-T80” modification with flange are also installed onto cleaning pigs “VOSTOK-D4T”, “VOSTOK-D6T”, “VOSTOK-M4T” and “VOSTOK-MDT”.

For pipelines of  $\varnothing=273$  mm and 325 mm transmitters of “VOSTOK-T80B” modification are also installed onto monoblock cleaning pigs “VOSTOK-3DT”, “VOSTOK-4DT” and “VOSTOK-5DT”.

### TRANSMITTER “VOSTOK-T200” (FIGURE “80” CORRESPONDS TO BODY DIAMETER OF 219 MM)

For pipelines of  $\varnothing=720$  mm, 820 mm, 1020 mm, 1220 mm и 1420 mm transmitters of “VOSTOK-T200” modification with flange are installed onto cleaning pigs “VOSTOK-D4T”, “VOSTOK-D6T”, “VOSTOK-M4T” and “VOSTOK-MDT”.

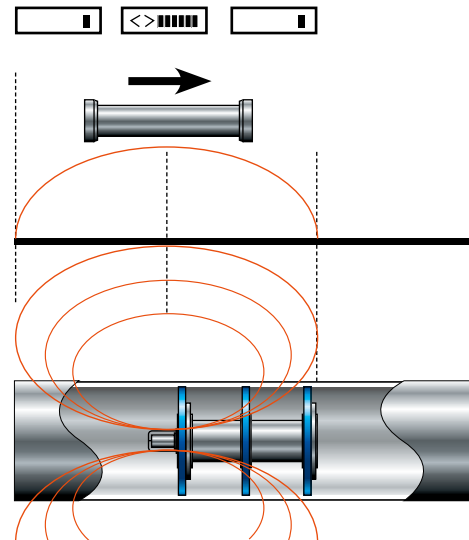

Graph of “VOSTOK-T” transmitter’s signal behavior and primary coverage, given the parallel arrangement of “VOSTOK-NL” low-frequency mole’s aerial and the distance between the receiving aerial and the radiation coil.

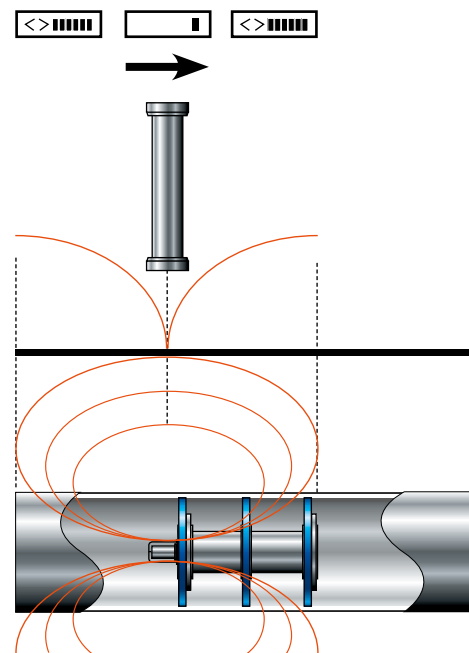

Graph of “VOSTOK-T” transmitter’s signal behavior and primary coverage, given the vertical arrangement of “VOSTOK-NL” low-frequency mole’s aerial and the distance between the receiving aerial and the radiation coil.

P R O D U C T I O N

**Parameters of the transmitters "VOSTOK-T"**

Parameter description	Transmitter modification			
	T40	T60	T80	T200
Maximum ambient pressure, mPa	10			
Optional	20			
Electromagnetic signal emission frequency, Hz	13, 22 and "SEMIGOR" signal			
Signal transmission time (set prior to the launch into the pipeline)	1:1, 1:2, 1:3, 1:6 (optional) double capacity 1:1, 1:2, 1:3, 1:6 (optional) continuous, double capacity			
Over-the-air distance, which allows the low-frequency mole's aerial to steadily receive the transmitter's signal (given the aligning arrangement of the mole's aerials and the transmitter, as well as interference elimination)	10	10	25	27
Transmitter's running time at ambient temperature of +20°C, hours	60/24	75	250	1000
Power source and its quantity – Alkaline battery 1,5 V – accumulator 24 V	3 (4) -	6 -	6	- 2
Battery or accumulator type	AA	AA	D	DJW
Operating temperature range Operating temperature range for extreme conditions	-20 ... +85°C -40 ... +85°C			
Net weight (w/o disks and cups), max, kg	1,4	3,5	9,0	18
Critical dimensions, diameter x length, w/o flange (w/flange), mm	41x190 (207)	62 (92) x370	80x440	219 (285) x782
Ability to activate the power supply w/o opening the transmitter cover	Нет	Нет	Да	Нет
Cleaning pig's motion speed range, m/sec	до 6			

**Run-in clearance for transmitter-integrated cleaning pigs in pipeline branch connections (swing radius)**

Type of a cleaning pig	Modification of a transmitter	Pipeline diameter, mm				
		114	159 (168)	219	273	325
<b>Monoblock transmitter-integrated cleaning pigs</b>						
"VOSTOK-3DT"	"VOSTOK-T40B"		1,5	1,5	1,5	1,5
"VOSTOK-4DT"		1,5	1,5	1,5	1,5	
"VOSTOK-5DT"		3,0	3,0	3,0	3,0	
"VOSTOK-3DT"	"VOSTOK-T60B"			1,5	1,5	1,5
"VOSTOK-4DT"				1,5	1,5	1,5
"VOSTOK-5DT"				3,0	3,0	3,0
"VOSTOK-3DT"	"VOSTOK-T80B"				1,5	1,5
"VOSTOK-4DT"					1,5	1,5
"VOSTOK-5DT"					3,0	3,0

**Monoblock transmitter-integrated cleaning pigs**

Type of a cleaning pig	Monoblock transmitter-integrated cleaning pigs Type of a cleaning pig	Pipeline diameter, mm				
		114	159 (168)	219	273	325
"VOSTOK-D4T"	"VOSTOK-T40B"	1,5	1,5			
"VOSTOK-D6T"		1,5	1,5			
"VOSTOK-M4T"		1,5	1,5			
"VOSTOK-MDT"		1,5	1,5			
"VOSTOK-D4T"	"VOSTOK-T60B"		1,5			
"VOSTOK-D6T"			1,5			
"VOSTOK-M4T"			1,5			
"VOSTOK-MDT"			1,5			
"VOSTOK-D4T"	"VOSTOK-T80B"			1,5	1,5	1,5
"VOSTOK-D6T"				1,5	1,5	1,5
"VOSTOK-M4T"				1,5	1,5	1,5
"VOSTOK-MDT"				1,5	1,5	1,5

**Transmitter-integrated cleaning pigs with metal body**

Type of a cleaning pig	Modification of s transmitter, onto with the disks/ cups are installed	Pipeline diameter, mm		
		325 (12")	377 (14")	426 (16") и больше
"VOSTOK-D4T"	"VOSTOK-T80"	3,0	3,0	1,5
"VOSTOK-D6T"		3,0	3,0	1,5
"VOSTOK-M4T"		3,0	3,0	1,5
"VOSTOK-MDT"		3,0	3,0	1,5

**Transmitter-integrated cleaning pigs with metal body**

Type of a cleaning pig	Modification of a transmitter, onto with the disks/cups are installed	Pipeline diameter, mm				
		720	820	1020	1220	1420
"VOSTOK-D4T"	"VOSTOK-T200"	1,5	1,5	1,5	1,5	1,5
"VOSTOK-D6T"		1,5	1,5	1,5	1,5	1,5
"VOSTOK-M4T"		1,5	1,5	1,5	1,5	1,5
"VOSTOK-MDT"		1,5	1,5	1,5	1,5	1,5



# DEVICES FOR MONITORING THE CHARACTERISTICS OF OPERATING PROCEDURES



## COMBINATION DOWNHOLE PRESSURE GAGE “VOSTOK-MS” (GE-ODAS-511)

The device is designed for measuring the pressure and temperature and further recording of the measured data in an electronic memory. It has got a sealed case, withstanding the pressure of up to 1200 kgf/cm<sup>2</sup>. It may be used in various industrial fields for the purpose of researching pressure and temperature alteration processes.

### ADVANTAGES

1. Continuous operation within 5 years, without replacing the power source with measurement resolution of 10 sec.
2. Sealed (undismountable) design of the device does not require service (for instance, change of packing rings, which is included in maintenance for most of existing devices).
3. During the data read-out single-wire interface is used, without dismantling the device, via USB 2.0 port.
4. The device is meant for conducting the measuring procedures within the temperature range of 0 – +150°C with fractional error for pressure channel of 0,15% and absolute error for temperature channel of ±0,5°C. There are modification of the device with specified temperature range of +165°C and +180°C.
5. There are 3 device operation modes, available for the user and meant for gathering information:
  - mode of gathering information in all channels of the device with preset measurement resolution, until the memory is full;
  - mode of launching the device in accordance with preset pressure or temperature bar, until the memory is full;
  - “warm start” mode enabling recording of the data into the device in case of rising ambient pressure, which exceeds the set pressure bar, and turning on the low-consumption state in case of the pressure drop.

There is an option of programming the device’s operation following the Client’s algorithm, without any additional modifications.

**CERTIFICATE OF CONFORMITY**  
№ POCC RU.MH10.H00050

### KEY TECHNICAL PARAMETERS

Parameter description, unit	Value
Device’s measuring channels	Pressure*, Temperature*
Pressure cell type	Silicon-on-sapphire
Battery life with measurement resolution of 10 sec, yrs	5 (Ø= 32 mm), 3 (Ø=28 mm)
Data transfer port	USB 2.0
Memory resource, number of pressure and temperature points	932 000 *
Measurement resolution range, sec	0,18 – 15300* (4,25 hours)
Maximum pressure, mPa	100
Fractional error for pressure channel within the Specified temperature range, % URL	0,15*
Resolution capacity for pressure channel, % URL	0,0003
Pressure value drift, max %/year	0,05
Operating temperature range, °c	-40 ... +150/*, -40... +165/ , -40...+180
Specified temperature range, °c	0 ... +150/*, 0... +165/, 0...+180
Absolute error for temperature channel, °c	±0,5
Maximum resolution capacity for temperature channel, °c	0,01
Critical dimensions: Ø/length, mm	32/403, 28/473

\* - parameter variations are possible

**IN-LINE RECORDER OF PUMPING PARAMETERS OF CONDUCTING THE PIPELINE INTERIOR CLEANING OPERATIONS “VOSTOK-VR” (POTOK-412)**

The recorder of pumping parameters is designed for measuring and further recording in an electronic memory the data regarding temperature (T), pressure (P) and differential pressure ( $\Delta P$ ) on a cleaning pig along the entire pipeline segment, on-line, with preset measurement resolution of 3 measurements per 1 sec.

The device is used for identifying the location of deposits and narrow segments of the pipeline, monitoring the progressions of a cleaning pig, monitoring the cleaning process, validating the pumping operation parameters.

“VOSTOK-VR” recorder is installed in the front of the cleaning pig. It is equipped with a temperature-sensitive element and 2 pressure-sensitive elements and is meant for recording the data along the pipeline segments of up to 500 km long, with running period of min 30 days. The device functions without any service (without replacing the power source) within 2 years with measurement resolution of 10 sec and higher. Upper level software displays the recorded data in graphical and tabular format.

Report format:

- temperature graph of the product along the entire pipeline route (min, average and max);
- absolute pressure graph of the product along the entire pipeline route (min, average and max);
- differential pressure graph of the cleaning pig during its progression along the entire pipeline route (min, average and max);
- the device’s running time from the pig launcher station to pig catcher station;
- acceleration curve in three directions (when necessary);
- reference of real-time scale to the distance covered by the cleaning pig, based on the data regarding the product flowrate, external odometers or embedded accelerometers.

Using the pipeline data recorder “VOSTOK-VR” allows researching the building mechanisms and locations of deposits in pipelines, as well as their accumulation rate, during periodic inspections.

Using the data regarding the parameters of transported product (temperature T and pressure P), as well as information on differential pressure  $\Delta P$  on a cleaning pig in any section of the pipeline, together with carrying out the hydraulic calculations and physical-chemical research of the transported product and in-line deposits, gives an opportunity to analyze the pipeline deposits more comprehensively, as well as identify the influence of the product transportation mode and its chemical compound on the possibility of building and accumulation rate of in-line deposits.

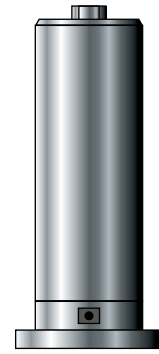

**CERTIFICATE OF CONFORMITY**  
№ POCC RU.AF99.H00105



Cup-disk cleaning pig “VOSTOK-M4” with “VOSTOK-VR” installed in the front, prior to the trial.

**KEY TECHNICAL PARAMETERS:**

Parameter description, unit	Value
Device’s measuring channels	Pressure, Temperature, Acceleration*, Distance*
Pressure cell type	Silicon-on-sapphire
Battery life with measurement resolution of 10 sec, yrs	2
Data transfer port	USB 2.0
Memory resource, number of pressure and temperature points	559000 *
Measurement resolution range, sec	0,18 – 15300* (4,25 hours)
Maximum pressure, mPa	20
Fractional error for pressure channel within the Specified temperature range, % URL	0,15 *
Resolution capacity for pressure channel, % URL	0,0003
Pressure value drift, max %/year	0,05
Operating temperature range, °c	-20 ... +85
Absolute error for temperature channel, °c	±0,5
Maximum resolution capacity for temperature channel, °c	0,01
Weight, kg	3,5

\* - parameter variations are possible





**IN-LINE RECORDER CRUDE OIL PIPELINE TRIALS**

Double trials of in-line recorder "VOSTOK-VR" were performed in the "Tashkinovo-Shushnur" crude oil pipeline (Ø=325 mm, 23 km long) of "Bashneft-Dobycha". During the trials along the entire pipeline route the device recorded and stored in the electronic memory the data re-garding the product temperature  $t^{\circ}$ , pipeline pressure P1 ("in front of") and P2 ("at the back of") the cleaning pig (along the route) with measurement resolution of 1 sec. After processing the data the temperature  $t^{\circ}$ , pressure P1 and P2, as well as the differential pressure  $\Delta P = P2 - P1$  were graphed. Differential pressure  $\Delta P$  graph demonstrated several significant changes in amplitude, which correspond with the time of cleaning pig's passing through the line gate valve of the pipeline in record time and with the number of the mentioned valves (which showed the changes in differential pressure  $\Delta P$  while cleaning pig passing through them) in number of these peak values of  $\Delta P$ . Several significant changes in amplitude  $\Delta P$  were also recorded, which indicate the presence of connection branches (turns) of  $R=1,5 D$  at  $90^{\circ}$ , as well as the obstructions in the pipeline.

Graphs of pressure "in front of" and "at the back of" a cleaning pig and the pressure differential during the 1st trial along the entire pipeline route. Cleaning pig's pressure loss in passing of the cleaning pig through the valves.

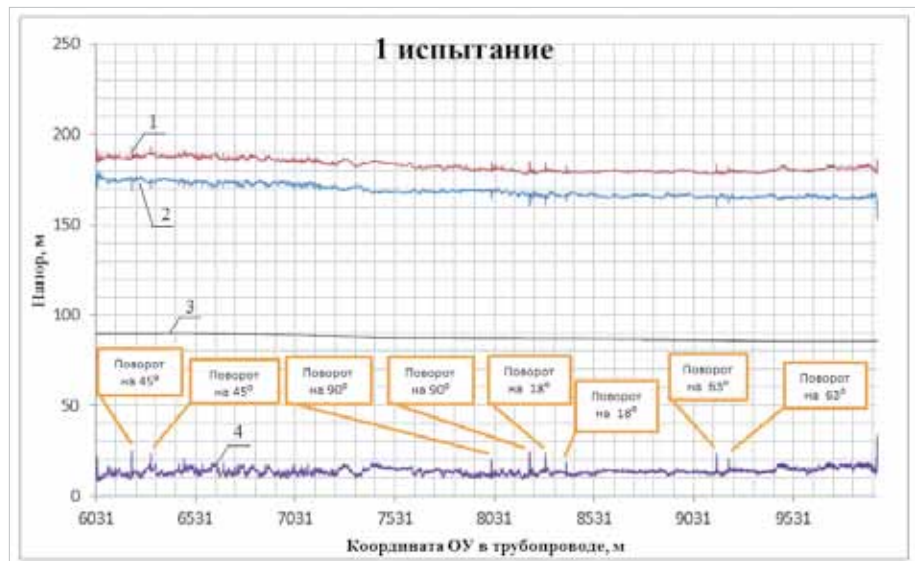
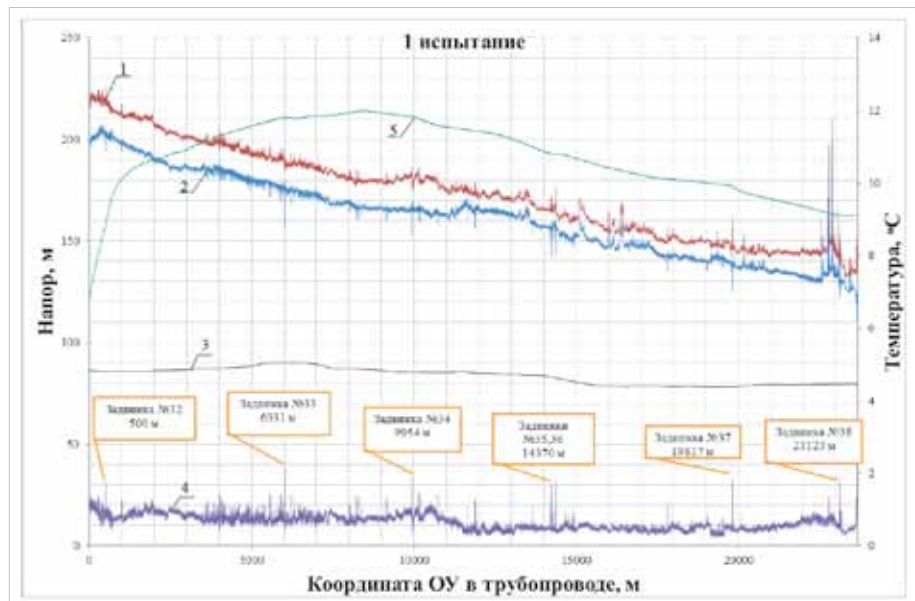

Cleaning pig's pressure loss in passing through the pipeline turns in the segment between the valves 33 and 34 (6031 – 9954 m).

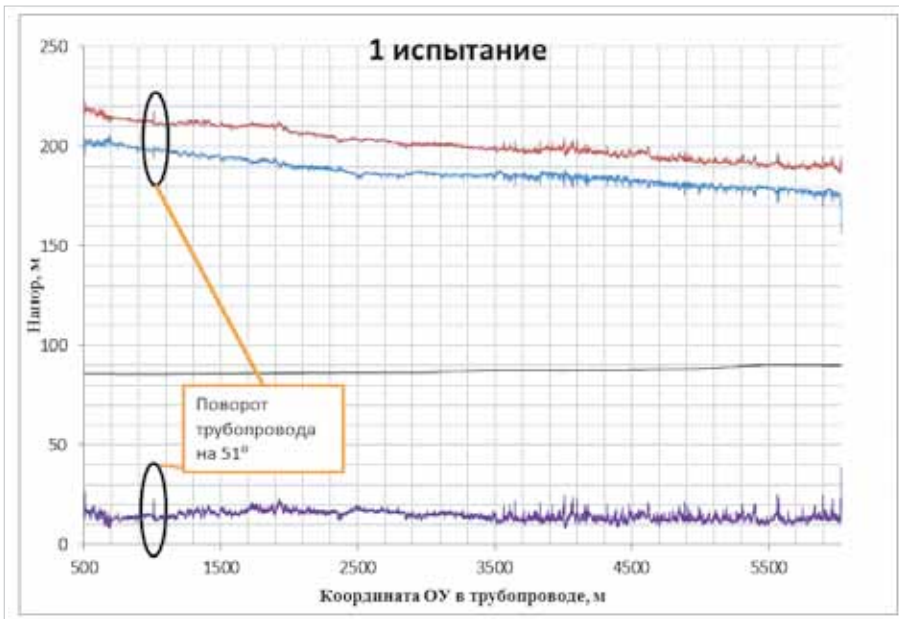

Pressure loss in passing through the turn in the segment between the valves 32 and 33 (500 – 6031 m) during the 1st trial.

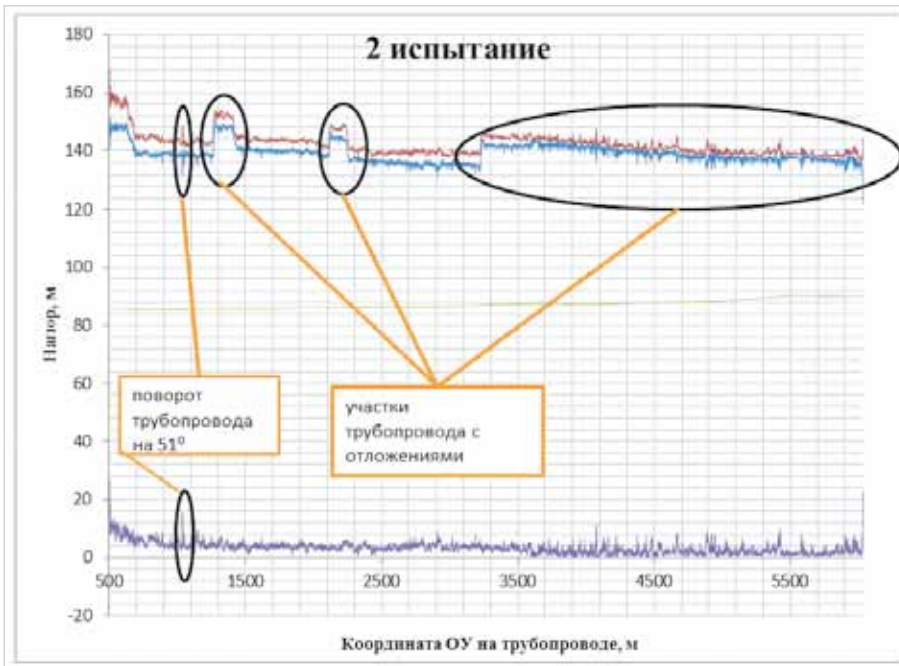

Pressure loss in passing through the turn and in areas of asphalt, resin and paraffin deposits (1270-1430 m, 2100-2250 m and from 3250 m and farther) after 3,7 months of 1st trial.

## COMPONENTS OF CLEANING PIGS



### CUPS AND DISKS

Cups and disks are made of polyurethane or oil-petrol-resistant rubber of various density.

Material	Resource, km			
	In dry pipe	In aqueous medium	In oil products	In crude oil
Polyurethane	55-75	140-160	160-180	200-220
Rubber	50-70	100-120	120-140	120-160
Polyurethane with solid insertion pieces	180	200	200	200





PRODUCTION

## COMPONENTS OF CLEANING PIGS



### ADDITIONAL ATTACHMENTS

Attachments extend the functionality of cleaning pigs.



**Brushing unit** is used in case of cleaning the pipeline interior from scale, incrustation and incrustant asphalt deposits.

**Magnetic unit** is used in case of cleaning the pipeline interior from scale, electrode residue and metal fractions.

**Gauging unit** is used for calculating the minimum run-in clearance (maximum restriction) of a pipeline segment.

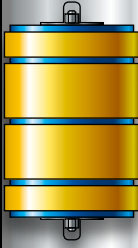
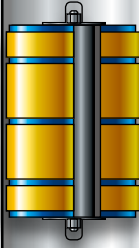

## FIELD OF APPLICATION OF CLEANING PIGS

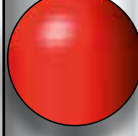
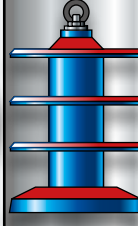
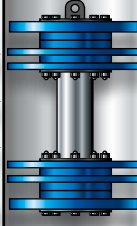
PIPELINE Ø, MM	89-1420	89-720	159-720	89-377	89-273	57-273	89-325	89-1420
								
CLEANING PIGS' TYPE	VOSTOK-PM VOSTOK-PU	VOSTOK-PB	VOSTOK-PBT	VOSTOK-PP	VOSTOK-PR	VOSTOK-SHP	VOSTOK-HDT	VOSTOK-D6
PIPELINES								
UPSTREAM (PRES-SURE) CRUDE OIL LINES	✓	✓	✓	✓	✓	✓	✓	✓
UPSTREAM (PRES-SURE) GAS LINES		✓	✓	✓	✓	✓	✓	✓
OIL-GATHER-ING MAINS	✓	✓	✓	✓	✓	✓	✓	
GAS-GATHER-ING HEAD-ERS		✓		✓	✓	✓	✓	
CRUDE OIL TRANSFER LINES	✓	✓	✓				✓	✓
GAS TRANSFER LINES		✓	✓					✓
OIL-PRODUCT TRANSFER LINES	✓	✓	✓				✓	✓
WATER SUPPLY LINES	✓	✓	✓				✓	✓
INDUSTRI-AL PIPE- LINES OF OIL AND GAS TREATING DEPART-MENTS	✓	✓	✓	✓	✓	✓	✓	



89-1420	89-1420	89-530	89-530	89-530	219-530	89-530	89-530	114-325	325-1420
VOSTOK-MD	VOSTOK-M4	VOSTOK-MM	VOSTOK-PD	VOSTOK-KSK	VOSTOK-KL	VOSTOK-KS	VOSTOK-PS	VOSTOK-D6T	VOSTOK-D6T
✓	✓	✓	✓	✓	✓	✓	✓	✓	✓
✓	✓			✓		✓	✓	✓	✓
		✓	✓	✓	✓	✓	✓		
		✓		✓		✓	✓		
✓	✓			✓	✓	✓		✓	✓
✓	✓			✓				✓	✓
✓	✓			✓	✓	✓	✓	✓	✓
✓	✓		✓	✓	✓	✓		✓	✓
				✓		✓	✓		



## TRACKING THE LOCATION OF PIGS STUCK IN THE PIPELINE

### Tracking the location of stuck pigs is conducted as follow-ing:

Monitoring the magnetic record of the pipeline segment from the ground surface (the presumable location of the pig's stoppage) by the "ZOND-SKAN" device with further reflection of the former on the device's display and simultaneous recording of the distance, covered by the operator, using the embedded GPS-receiver in automated op-eration mode, as well as presenting the information on GPS-positioning of the pig stuck in the pipeline.

1. Launch of the 2nd transmitter-integrated pig into the pipeline, tracking its running at check points with further identifying the 2nd pig's stoppage location using the low-frequency mole, proceeding on the assumption that the 2nd pig stops at the same spot, as of the 1st one, recording the GPS-positioning of the pig stuck in the pipeline.



## VISUAL PIPELINE INSPECTION

The technology of visual inspection involves conducting the following operation stages:

**1 stage** – inspecting the location of coating damages and revis-ing the pipeline using noncontact magnetometric method (exposing the pipeline spots with abnormal magnetic field, as well as their posi-tioning, following the regulation document 102-008-2002).

**2 stage** – pitting the pipeline in locations of coating damages and abnormal magnetic field.

**3 stage** – 3D-positioning of the pipeline.

**4 stage** – conducting the visual and measuring checks (coating condition, thickness of the coating and adhesion, protective properties of the coating) with integral estimate, using noncontact pipeline cur-rent measurement.

**5 stage** – selective measuring of pipe wall's thickness and hardness.

**6 stage** – selective measuring of circumferential weld geomet-rics (upon the visual and measuring checks) and circumferential weld parameters (upon the ultrasonic inspection).

**7 stage** – compiling the technical report, calculating the residual life and conducting industrial safety expert review.

The technology of monitoring the external coating integrity and the pipeline condition using noncontact magnetometric method is ap-plied by patrolling the pipeline route by the operator. Other parame-ters' monitoring (excluding acoustic emission control) is conducted by measuring and inspecting the bore pits.



## TECHNOLOGY OF IN-LINE INSPECTION (FOR PIPELINES OF $\varnothing=159-1420$ MM)

**The technology of in-line inspection involves conducting the following stages:**

**1 stage** – recurrent cleaning of the pipeline interior, using cleaning pigs (equipped with brushing and magnetic units, primary and fine purification pigs), from foreign objects, scale, electrodes and deposits. The cleaning pigs are equipped with the transmitter for the purpose of monitoring their running and identify the location in case of the stoppage.

**2 stage** – gauging the pipeline with the pig equipped with the gauging unit (gauging disks of various size), followed by issuing the decision on possible profile logging.

Prior to the launch of smart pigs the pipeline route is marked. Minimum distance between the markers is 1–2 km.

**3 stage** – pipeline profile logging using the multi-channel ge-ometry tool with presentation of express-report and issuing the deci-sion on possible conduction of inspection with magnetic flaw-detecting devices of longitudinal magnetization (MFL) and transver-sal magnetization (TFI), as well as providing recommendations on elimination of geometry flaws, which block the passage of magnetic flaw-detection devices.

**4 stage** – flaw detection of the pipeline, circumferential and longitudinal welds using magnetic flaw-detection devices of longitu-dinal magnetization (MFL) and transversal magnetization (TFI) with presentation of express-report on the inspection of intolerable flaws requiring immediate repair (elimination).







Monitoring of quality and completeness of recording the data on the segment is conducted immediately after each run during the field work. Upon revising the results, the decision on possible check run of the smart pigs is taken. All runs of the in-line devices are reflected in audit acts.

**5 stage** – compiling the technical report, based on the results of in-line inspection, providing recommendation, as well as calculating the residual life and conducting industrial safety expert review (when necessary).

The preliminary report on in-line inspection results is sent to the Client in 15 calendar days, which includes the pipe stringing log, marking points' positioning and the list of most dangerous flaws.

The final report is sent to the Client in 30–45 calendar days, indicating all pipeline elements, detected longitudinal and circumferential welds, as well as all detected flaws providing their type and geometrical dimensions with danger level estimate. Recommendations on external inspection deadlines and repair methods are also provided. Estimation of flaw danger levels is conducted in accordance with Russian and international standards. GPS-positioning of the flaws is also provided, if necessary.

4-STAGE SYSTEM OF PIPELINE INSPECTION

We suggest using the 4-stage system of pipeline inspection, when conducting the in-line inspection.

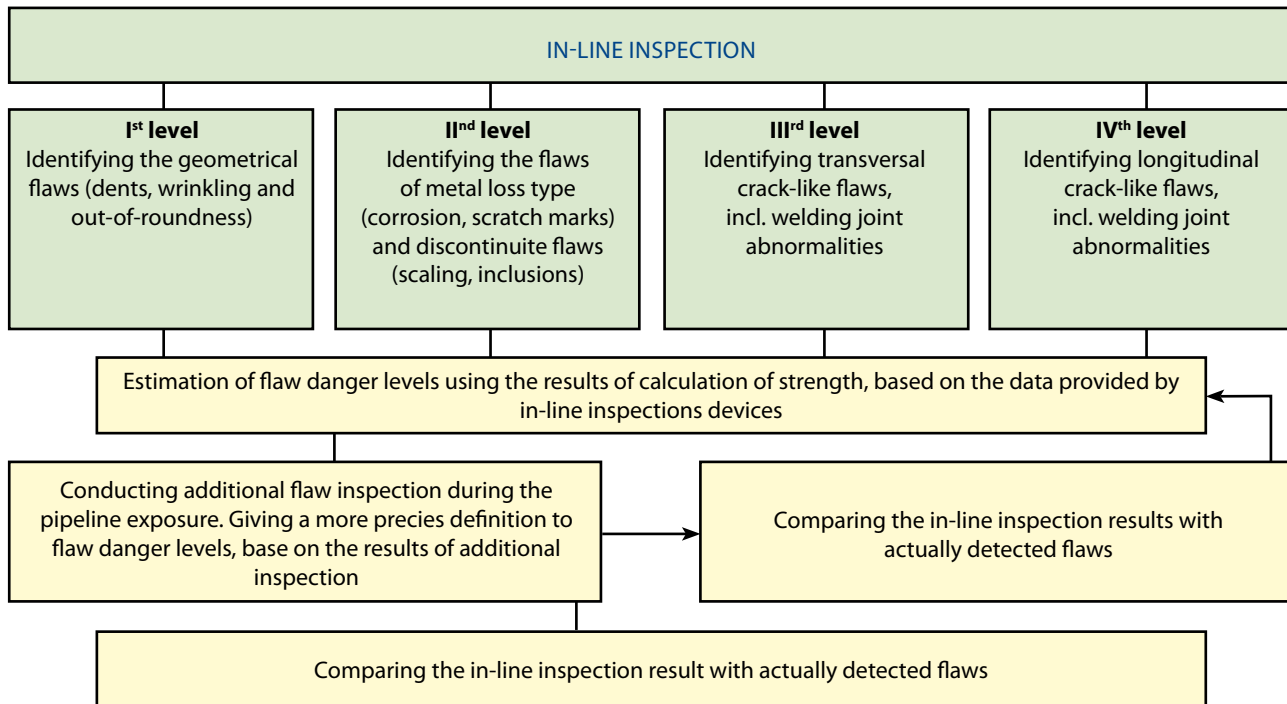

**On the 1st level** of inspection the multi-channel geometry is used and the pipeline geometry monitoring is carried out: detection, identification and measuring the parameters of geometry flaws and pipeline bend angles, as well as existence of peculiar details – backing rings and other inward-protruding pipeline elements; measuring the positioning of radial welding joints and detected flaws.

**On the 2nd level** magnetic flaw-detection device of longitudinal magnetization (MFL) is used and the monitoring of the pipeline walls takes place: detection, identification and measuring the parameters of metal loss (massive and pitting corrosion), scratch marks, tears and scaling (including the ones exposing on the surface), dents, wrinkling, fasteners and structural parts.

**On the 3rd level** magnetic flaw-detection device of longitudinal magnetization (MFL) is used and the monitoring of the pipeline circumferential weld takes place: detection, identification and measuring the parameters of cracks and crack-like flaws in weld and weld-adjacent zones, inclusions, pores and other weld flaws.

**On the 4th level** magnetic flaw-detection device of transversal magnetization (TFI) is used and the monitoring of the pipeline longitudinal weld takes place: detection, identification and measuring the parameters of cracks and crack-like flaws in weld and weld-adjacent zones, inclusions, pores and other weld flaws.

**Note:** 2nd and 3rd levels of inspection are carried out upon the launch of flaw-detection device of longitudinal magnetization.

Calculations of residual life, calculations of strength (maximum pressure) and industrial safety examination are carried out additionally, if necessary.

Since 2006 we have conducted the in-line and pipeline industrial safety examination (including submerged crossing) for "Bashneft", "Bashneft-Dobycha", "Udmurtneft", "Belkamstroy", "Belkamneft", "Naftatrans", "Surgutneftegaz", "Otradny" support base and others.

Flaws and pipeline elements, subject to detection by in-line detection devices.





IN-LINE INSPECTION TECHNICAL FACILITIES

**GAUGING PIG WITH GAUGING UNIT**

The device is designed for inspecting the minimum pipeline run-in clearance of  $\varnothing=159-1420$  mm with the purpose of issuing the decision on possible launch of the geometry tool.

**GEOMETRY TOOLS PRT FOR PIPELINES OF  $\varnothing=159-1420$  mm**

“PRT”-type electronic geometry tools are used for measuring the inside pipeline diameter and detecting the pipeline’s geometry flaws (dents, wrinkling, out-of roundness, etc.). There are modifications with embedded systems of geographical mapping of the pipeline and systems of quantitative measurement of de-posits in the pipeline interior.

**FLAW-DETECTION DEVICES DMT (OF LONGITUDINAL MAGNETI-ZATION MFL) FOR PIPELINES OF  $\varnothing=159-1420$  mm**

“DMT”-type magnetic flaw-detection devices of high resolution capacity are used for registering and measuring the signals of longitudinal leakage flux in locations of pipeline walls’ flaws. They are meant for detecting, identifying the location and measuring the size of massive and pitch corrosion flaws, radial weld flaws, transversal cracks and other flaws of transversal pointing, as well as pipeline elements.

**FLAW-DETECTION DEVICES DMTP (OF TRANSVERSAL MAGNETI-ZATION TFI) FOR PIPELINES OF  $\varnothing=159-1420$  mm**

“DMTP”-type magnetic flaw-detection devices of high resolution capacity are used for registering and measuring the signals of transversal leakage flux in locations of pipeline walls’ flaws. They are meant for detecting, identifying the location and measuring the flaws of longitudinal pointing including singular longitudinal pipeline elements and other pipeline flaws of longitudinal pointing, as well as stress-corrosion cracking (SCC flaws).

**INTROSCOPES MFL+ FOR PIPELINES OF  $\varnothing=159-1420$  mm**

“MFL+”-type magnetic in-line introsopes are capable of photo-quality detecting all flaws of any pointing type of the pipe-line interior, including pipeline geometry flaws. The accuracy of flaw detection, as well as the measurement of their size in the pipeline interior is not affected by the thickness of pipeline walls.





# TECHNOLOGY OF PIGGING LENGTHILY UNCLEANED PIPELINES

## SEQUENTIAL (STEP-BY-STEP) CLEANING

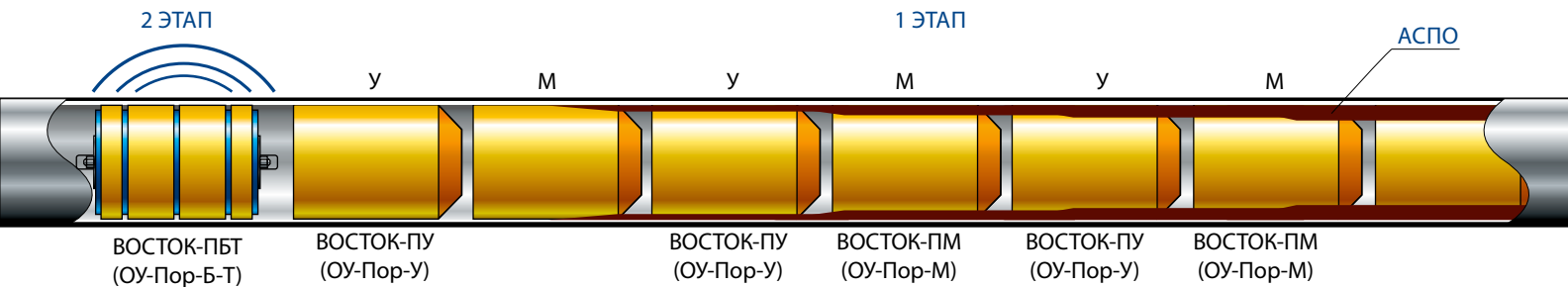

### Key cleaning concept – avoiding the deposit-plugging of the crude oil pipeline

Research the degree of deposit buildup on the pipeline wall along the entire length and assemble temporary cleaning pig launcher and catcher stations.

#### 1 stage – recurrent cleaning using **soft (S) and reinforced (R) foam cleaning pigs.**

During the 1st run, it is necessary to launch the “VOSTOK-PM” cleaning pig of diameter smaller than that of the cleaned pipe-line, with density= 30-40 kg/m<sup>3</sup>, and track the pig’s running using the acoustic device “Sensor”. Later on, the diameter and the density of foam cleaning pigs each time should be adjusted according to the results of previous pig run, i.e. after removal of the pig from the pipeline the information on its condition (degree and kind of damage) should be analyzed, as well as the type, quantity and compound of foreign objects and deposits extracted from the pipeline.

Cleaning of the crude oil pipeline **with foam cleaning pigs should be conducted until the degree of removed pigs’ changes (damages) is minimal.**

**2 stage** – recurrent cleaning using “VOSTOK-PBT” “Pun-cheon”-type foam cleaning pig, installed on transmitter’s body.

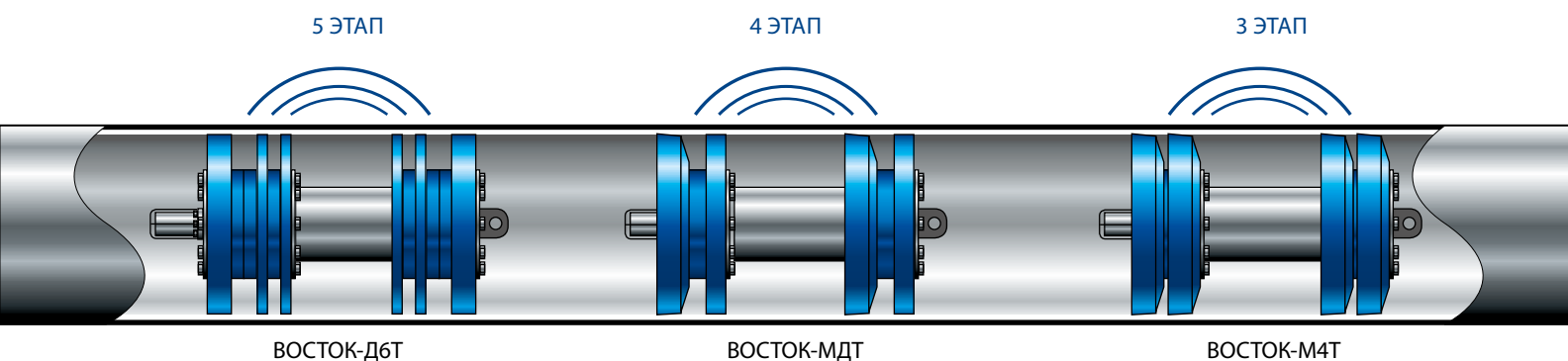

**3-5 stages** – cleaning using “VOSTOK-M4T”, “VOSTOK-MDT” and “VOSTOK-D6T” cleaning pigs **with conical and straight polyurethane cups and disks** (conical cups are replaced with straight disks between the runs).

**6 stage** – check run of the cleaning pig with polyurethane disks and brushing unit.

At all stages of cleaning the crude oil pipeline, the pigs should be tracked using the acoustic mole “VOSTOK-AL” and low-frequency mole “VOSTOK-NL”.

## TECHNOLOGY OF SUPERVISING THE SUBMERGED CROSSING



Supervision of submerged crossing (SC) is conducted using specific technical facilities. The main and auxiliary branches of SC should be equipped with launcher and catcher stations for in-line cleaning and smart pigs. These are key stages of supervising the SC using the in-line facilities of technical inspection:

**1 stage** – cleaning the SC interior from paraffin and foreign objects with cleaning pigs. The quality of cleaning should correlate with recommendations of the companies, which conduct the supervision using the in-line facilities of technical inspection.

**2 stage** – calculating the minimum run-in clearance of the SC pipeline along its entire length. The minimum run-in clearance is calculated by launching a specific cleaning pig – a gauging pig with measuring disks (plates) suitable for the given SC diameter.

**3 stage** – receiving of data regarding the pipeline’s inside geometry along the entire length of inspected SC, launching the geometry tool for the purpose of detecting the geometry faults. The possibility of geometry tool launch is identified according to the existing situation on the SC, considering the pattern of gauging pig’s plate deformation.

Further inspection of SC walls includes the usage of self-contained in-line smart pigs or devices, used for inspection of crude oil and gas wells on logging cable.

**4 stage** – pulling the logging cable or the wire cable from launcher station to catcher station, using the specific separator.

**5 stage** – identifying the actual high-altitude and horizontal position of the SC, using the inclinometer.

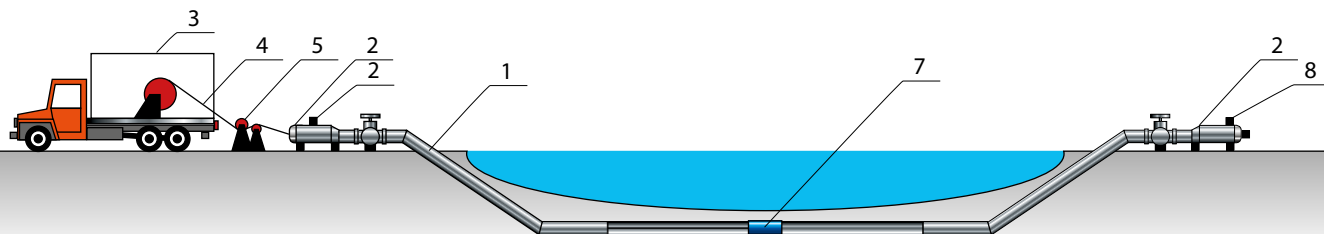

**Picture 1.** Pulling the logging cable or the wire cable through pipeline submerged crossing  
 1 – submerged crossing; 2 – cleaning pig launcher and catching station; 3 – logging unit (pulling unit);  
 4 – logging cable; 5 – belt-stretching rollers; 6 – inlet valve; 7 – cleaning pig; 8 – output valve.

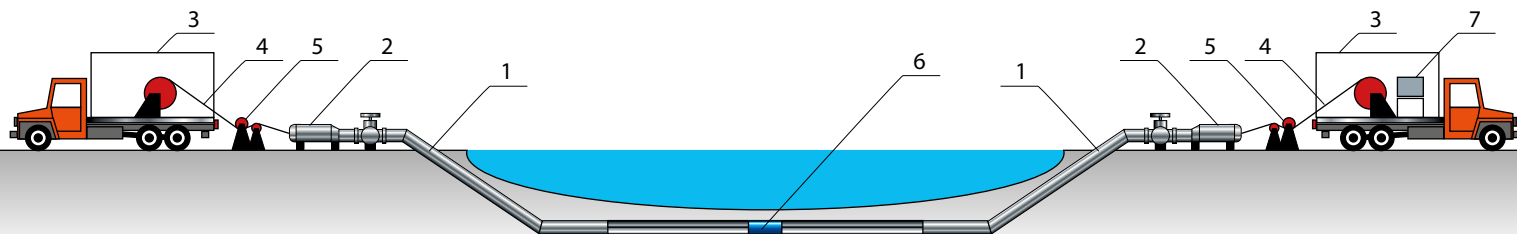

**Picture 2.** Inspecting the pipeline SC using the self-contained smart pigs and pulling them through the SC  
 1 – submerged crossing; 2 – cleaning pig launcher and catching station; 3 – logging units (pulling units);  
 4 – logging cable; 5 – belt-stretching rollers; 6 – inlet valve; 7 – smart pig; 8 – PC.

**6 stage** – defining the density (existence) of ground around the SC pipeline, as well as the average SC wall thickness, using the well gamma-flaw detector.

**7 stage** – measuring the size and geometrical shape of the SC pipeline, using the well acoustic device. Upon the results of SC inspection, the pipeline's residual life is calculated, as well as industrial safety examination, registering the results in Russian Federal Service for Environmental, Technological and Nuclear Supervision.

The technology is developed by "VOSTOKneftegaz" together with "Geofizika" and used while inspecting the SC of "Bashneft", "Udmurtneft" and "Belkamneft" pipelines.

The technology is agreed by Russian Federal Service for Environmental, Technological and Nuclear Supervision and approved by the Ministry of Industry and Energy of Russian Federation.

#### PARAMETERS, CONSIDERED DURING THE INSPECTION

1. Errors of SC pipeline geometry (wrinkling, dents, bellying, swing radii).
2. Actual 3D-positioning of SC.
3. Existence of bare spots in SC pipeline (according to the density of ground around the pipe-line).
4. Interior profile of the SC pipeline.
5. Thickness of the SC pipeline wall (corrosion damages).
6. Modeling the interior of the SC pipeline.
7. Weld monitoring.



# TECHNOLOGY OF PIGGING, WITH PERIODIC REMOVAL OF DEPOSITS USING THE PLUNGER

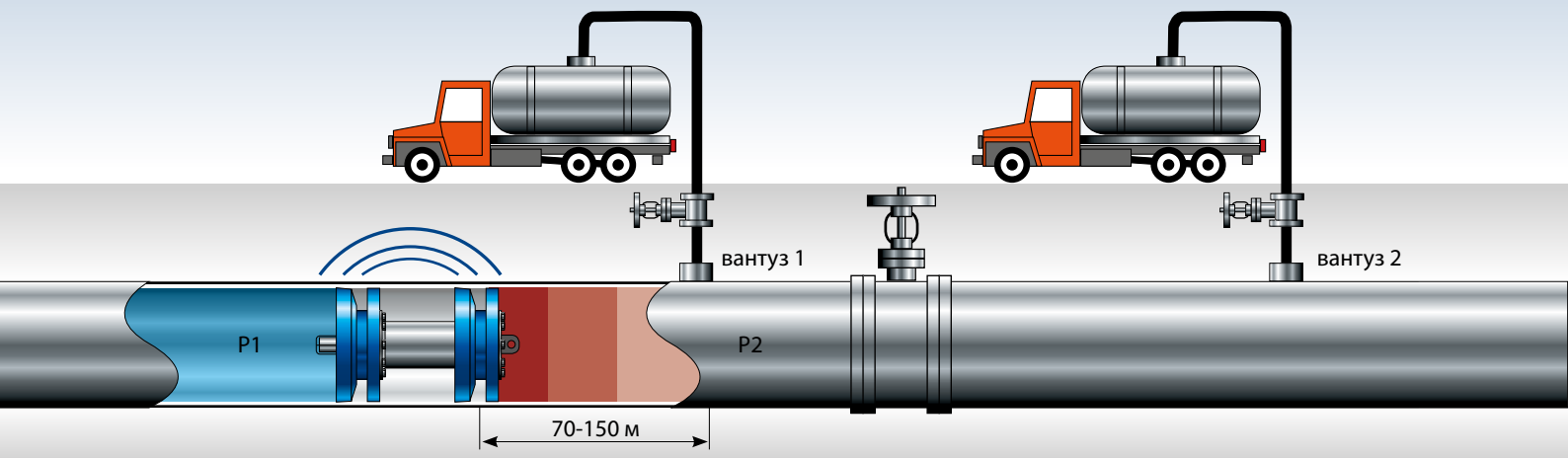

RF PATENT  
№ 2400315

**1 stage** – launch the transmitter-integrated cleaning pig “VOS-TOK-MDT” into the pipeline and track its location following the electro-magnetic signals sent by the transmitter and “VOSTOK-AL” device, as well as pipeline capacity (Q), primary pipeline pressure (P1) and pressure differential ( $\Delta P$ );

**2 stage** – it is acceptable to stop the oil pumping in case of drop in capacity by 30–50% and pressure P increase to the maximum.

**3 stage** – using the “hot tap” method, rig in the plunger 1 at a distance of 70–150 m from the location of “VOSTOK-MDT”, assemble the process pipeline and prepare oil trucks for oil and paraffin reception.

**4 stage** – launch the pumping and displacement of paraffin until the moment of pure crude oil seepage.

**5 stage** – repeat previous steps until arrival of the “VOSTOK-MDT” cleaning pig into the catcher station.

**6 stage** – carry out the check run of “VOSTOK-MDT” or standard hard cleaning pig “VOSTOK-D6T” with polyurethane disks and brush-ing unit.

At all stages of cleaning the crude oil pipeline, the pigs are tracked using the acoustic mole “VOSTOK-AL” or “VOSTOK-ALR”, as well as the low-frequency mole “VOSTOK-NL” for the purpose of tracking and identifying the location of cleaning and smart pigs.

The technologies are developed using practical experience of cleaning lengthily uncleaned pipelines of “Rosneft-Stavropolneftegaz”, “Bashneft”, “Tatneft”, “Belkamneft”, “LUKOIL-Perm”, “Varyegannefte-gaz”, “LUKOIL-Komi”, “Orenburgneft”, “TNK-Nyagan” and others.





## TECHNOLOGY OF PIGGING AND GAUGING THE PIPELINE UPON ITS LAYING

Key concept – thorough cleaning of the laid pipeline from construction waste, electrode residue and foreign objects, as well as calculating the minimum run-in clearance, i.e. pipeline gauging. The technology includes mechanical cleaning of the pipeline, using cleaning pigs, run by the flux of air or process water (by agreement with the Client). The cleaning pig should possess a transmitter or, for pipelines of  $\varnothing=114$  mm, 159 mm, 219 mm, 273 mm and 325 mm, the transmitter-combined cleaning pig should be used. The process of cleaning and running of the cleaning pig is additionally monitored by the acoustic mole "VOSTOK-AL" or "VOSTOK-ALR".

Cleaning pigs may be equipped with brushing, magnetic or gauging units for the purpose of cleaning the pipeline interior from scale, electrode residue and metal fractions, as well as calculating the minimum run-in clearance of the pipeline.

The work includes the preparatory stage, the core stage and compiling the technical report (when necessary).

### 1. PREPARATORY STAGE

- 1.1. Research of the pipeline technical documents.
- 1.2. Inspection of the route, selection of check points for monitoring the cleaning pig's running.
- 1.3. Calculation of cleaning pig's transit time.
- 1.4. Preparation of cleaning pigs and monitoring devices.
- 1.5. Transportation of cleaning pigs and monitoring devices to the work location.
- 1.6. Verification of equipment operation capability at the work location.

### 2. CORE STAGE

- 2.1. Kicking of cleaning pig into the launcher station, station pressurization, and verification of transmitter operation capability after the pressurization.
- 2.2. Launch of the cleaning pig, control of its departure from the launcher station and start of tracking along the route.
- 2.3. Tracking the run of a cleaning pig in the pipeline, registering the time of its transit through the check points.
- 2.4. Control of the cleaning pig's arrival to the catcher station and identifying its location in the station.
- 2.5. Retrieving the cleaning pig from the catcher station, washing the pig.
- 2.6. Transportation of the equipment to the depot.



## CLEANING AND GAUGING THE PIPELINES

**1 stage** – cleaning the pipeline using the pigs of various designs, depending on the pipeline in-terior condition.

**2 stage** – pipeline gauging (calculating the minimum run-in clearance) using the gauging pig.

Cleaning and gauging works are conducted with simultaneous tracking and monitoring of the pigs' location.

## IN-LINE INSPECTION OF SHORT PIPELINE SEGMENTS

For inspection of short segments of pipeline of  $\varnothing=114-325$  mm in-line magnetic introsopes of MI-3H series are used (which are pulled on the cable). Introsopes of MI-3H series are designed for in-line inspection of line segments of crude oil pipelines, oil-product transfer lines, hot and cold water-supply pipelines, submerged pulled cross-ings and utility pipelines. The method of proce-dure is based on magnetization of pipeline walls from the interior using the electromagnet. The data regarding the detected flaws is recorded in computer memory. Pipeline wall inspection is car-ried out using the in-line magnetic introscope, which is pulled on the cable along the pipeline.

Parameters considered during the inspection: errors of pipeline geometry (wrinkling, dents, swing radii). Pipeline wall thickness, which ex-poses corrosion flaws, thermal and endurance cracks, cavities, loss of material, incomplete fu-sion.

The technology is tested by "Tatneft", "Mosvodokanal", "Bashneft" and others.



## CLEANING THE PIPELINES WITH INSIDE COATING AND "CELER" JOINTS

Cleaning the pipelines with inside coating and "Celer" joints from deposits is carried out by cleaning pigs. The technology is developed using practical experi-ence of cleaning the pipelines with inside coating and "Celer" joints.

The mentioned technology was used while cleaning "TNK-Nyagan", "LUKOIL-Uhtaneftegaz", "SANEKO" and other pipelines. We possess more than 20 years of expe-rience in cleaning the pipelines from deposits.

## CLEANING OF LENGTHILY UNCLEARED PIPELINES

During operation of pipelines various deposits of sand, salt, paraffin, asphalt, corrosion products, hydrates, pyrophores and emulsions occur, which may lead to nar-rowing of the run-in diameter, increase in operating pres-sure and cause an accelerated corrosion.

We present a wide range of specific methods of pipeline cleaning, which were developed for the purpose of solving all the mentioned above issues.

We carry out the following types of work:

- standard cleaning using cleaning pigs;
  - cleaning using cleaning pigs with magnifying di-iameter;
  - cleaning using mechanical pigs;
  - cleaning from solid particles using pigs in combi-nation with gel-pigs;
  - removal of saline deposits;
  - removal of paraffin deposits;
  - removal of pyrophore deposits and hydrates;
  - removal of corrosion products;
  - cleaning prior to the in-line inspection;
  - cleaning after the upon the pipeline laying;
  - cleaning in case of alteration of pipeline use;
  - cleaning with the purpose of pipeline decommis-sioning.
- Key cleaning concept – avoiding the deposit-plugging of the pipeline.

While conducting work of such kind, it is necessary to use the technology of step-by-step cleaning, especially when cleaning the lengthily uncleaned crude pipelines. The technology was developed by our associates as far back as in 1996, for the purpose of cleaning the sub-merged crossing of the "Vyatka-Ashit" pipeline ( $\varnothing=325$  mm) over the Kama river for "Bashneft", which has not been cleaned for 23 years.

The technology was upgraded using practical expe-rience of cleaning lengthily uncleaned pipelines of "Ros-neft-Stavropolneftegaz", "Bashneft", "Tatneft", "Belkamneft", "LUKOIL-Perm", "LUKOIL-Komi", "TNK-Nyagan", "Varyeganneftegaz", "Orenburgneft" and oth-ers.



## TRACKING THE LOCATION OF PIGS STUCK IN THE PIPELINE

Tracking the location of pigs stuck in the pipeline is carried out using the following technologies:

1. Monitoring the magnetic record of the pipeline segment from the ground surface (the presumable location of the pig's stoppage) by the "ZOND-SKAN" device with further reflection of the former on the device's display and simultaneous recording of the distance, covered by the operator, using the embedded GPS-receiver in auto-mated operation mode, as well as presenting the information on GPS-positioning of the pig stuck in the pipeline.

2. Launch of the 2nd transmitter-integrated pig into the pipeline, tracking its running at check points with further identifying the 2nd pig's stop-page location using the low-frequency mole, proceeding on the assumption that the 2nd pig stops at the same spot, as of the 1st one, recording the GPS-positioning of the pig stuck in the pipeline.

## IN-LINE INSPECTION OF CRUDE OIL AND GAS PIPELINES, OIL-PRODUCT TRANSFER LINES AND WATER-SUPPLY PIPELINES

We have cleaned and inspected over 3500 km of pipelines of  $\varnothing=159$  mm and higher, using the in-line flaw detectors.

The goal:

1. Inspecting the technical condition of the pipeline.  
2. Calculating strength (maximum pressure) and the residual life, based on the inspection results.

3. Industrial safety examination.

In-line inspection technology stages:

1. Preparatory work – identifying (based on the datasheet) and ensuring testability of inspected pipeline.

2. Cleaning of the pipeline interior from foreign objects, scale, electrodes, asphalt, paraffin and pyrophore deposits. The cleaning pigs are equipped with the transmitter for the purpose of monitoring their running and identify the location in case of the stoppage.

3. Gauging the pipeline – calculating the minimum run-in clearance and ensuring 70%-clearance of the outside diameter (i.e. removal of any flaws of geometry, exceeding 30% of outside

4. Pipeline profile logging – flaw detection of the pipeline (dents, wrinkles, out-of-roundness), measuring the swing radii. Ensuring 85%-clearance of the outside diameter (i.e. removal of any flaws of geometry, exceeding 15% of outside diameter) and minimum pipeline swing radius of 1,5 DN or 3 DN (swing radius should be equal of more than 1,5 DN or 3 DN, depending on the flaw detection device used after the profile logging).

5. Inspecting the pipeline using the in-line magnetic

(MFL and TFI) and/or ultrasonic flaw detection devices – detecting flaws like corrosion (external, internal, pitch and massive), stress-corrosion, scaling, structural parts, heteropointing cracks and other pipeline wall flaws.

6. Calculating strength and the residual life, industrial safety examination.

Since 2006 we have conducted the in-line and pipeline industrial safety examination (including submerged crossing) for "Bashneft", "Bashneft-Dobycha", "Udmurtneft", "Belkamstroy", "Belkamneft", "Naftatrans", "Surgutnefte-gaz", "Otradny" support base and others.

We possess more than 10 years of experience in in-line pipeline inspection.

## INSPECTING THE PIPELINE USING THE NONCONTACT MAGNETOMETRIC METHOD

Inspecting the technical condition of a pipeline using the noncontact magnetometric method (following the regulation document 102-008-2002) using the "ZOND-SKAN" device. "ZOND-SKAN" is a self-contained device designed for detecting flaws and illegal tapping of the operating pipeline from the ground surface without any contact.

Noncontact (ground-surface) detection of pipeline segments with flaws in metal and welding joints (cracks and crack-like flaws in welds, corrosion flaws, changes in pipeline wall thickness, dents, wrinkling and others), as well as illegal tapping is conducted using the high-resolution magnetometers "ZOND-SKAN", which was tested by "Uraltransnefteprodukt" and others. The field of application includes any type of underground wire cables of  $\varnothing=4"-58"$  (114–1420 mm).

"ZOND-SKAN" allows automatically controlling and registering the pipeline's magnetic record, with simultaneous recording of covered distance using the embedded GPS-receiver (geographic and metric positioning).

The data is recorded onto the USB storage device. The program contains expert system of detecting magnetic abnormalities, with great probability capable of interpreting the data (based on the results of scanning), located in zones of exposure of such abnormalities.

Inspection of the pipeline using "ZOND-SKAN" is conducted by one operator and does not require any changes in pipeline operation mode.

## VISUAL PIPELINE INSPECTION

The goal:

1. Obtaining the data regarding the wall thickness, coating, circumferential welds, chemical compound, mechanical characteristics of the pipeline material and weld joint.

2. Calculating the residual life.

3. Industrial safety examination, registering the results in Russian Federal Service for Environmental, Technological and Nuclear Supervision.

Parameters subject to measurement:

1. Actual 3D-positioning of the pipeline.

2. Selective measuring of pipe wall's thickness and hardness.

3. Adhesion of the pipeline coating.

4. Coating condition, thickness of the coating.
5. Protective properties of the coating) with integral estimate, using noncontact pipeline current measurement.
6. Areas of coating damages.
7. Selective measuring of actual thickness of pipeline in weld-adjacent zones.
8. Selective measuring of circumferential weld geometrics (upon the visual and measuring inspection).
9. Selective measuring of circumferential weld parameters (upon the ultrasonic inspection).

Nondestructive methods of control and inspection:

– ultrasonic thickness gauging and flaw detection;

– magnetic inspection;

– visual and measuring inspection;

– noncontact magnetometry;

– acoustic emission control;

– hardness testing;

– magnetic memory of metal;

– noncontact control of external coating integrity

Pipeline inspections are conducted using the nondestructive methods of control (excluding control of pipeline metal condition and research of the pipe-line chemical compound, as well as mechanical characteristics).

## DEVELOPMENT OF STANDARD-TECHNICAL DOCUMENTS, TECHNOLOGY REGULATIONS AND O&G LOSS NORMS

We have developed regulation the following documents, O&G loss norms and technology regulations:

– “Design and construction of submerged crossings of crude oil upstream pipelines” (“Bashneft”, 1998);

– “Rules of operation, maintenance control and overhaul of submerged crossings of crude oil upstream pipelines” (“Bashneft”, 1999);

– “Vertical steel tank inspection manual” (“Kaz-TransOil”, 2000);

– “Submerged crossings of crude oil upstream pipelines. Design and construction code of practice” (Ministry of Industry and Energy of Russian Federation, 2002);

– “Submerged crossings of crude oil upstream pipelines. Rules of maintenance and overhaul” (Ministry of Industry and Energy of Russian Federation, 2002):



– “Rules of technical inspection of crude oil transfer pipelines using in-line smart pigs” (“KazTransOil”, 2001);

– “Guidelines for replacing the crude oil from linear segments of crude oil transfer pipelines” (“Kaz-TransOil”, 2002);

– “Guidelines for abandoning and demolition of linear segments of crude oil transfer pipelines” (“Kaz-TransOil”, 2002);

– “Guidelines for operating procedure of pipeline submerged crossings surveillance, using downhole smart pigs” (2003);

– Technology regulations of O&G skimming and processing facilities’ operation: booster stations, sewage pumping stations, preliminary water removal units, pipeline commissioning stations: (“Orenburgneft”, “TNK-Nyagan”, “Samaraneftegaz”, “Gaz-promneft-Orenburg” an others, 2006, 2007, 2008, 2009, 2010, 2011, 2012, 2013, 2014);

– Rules of crude oil upstream pipelines operation (“Orenburgneft”, “Rosneft-Purneftegaz” and others, 2006, 2011, 2012, 2013, 2014);

– Substantiating the loss norms for associated gas and utilizing the crude oil for needs of the company (“Udmurtneft”, “Rosneft-Yuganskneftegaz”, 2006, 2009);

– Elaboration of qualifying tests and examining the personnel proficiency (“KazTransOil”, 2000);

– Guidelines for preventive maintenance and operation of upstream fiberglass pipes in the “Slavneft-Megionneftegaz” oilfield (2012);

for the purpose of preventive maintenance, overhaul and construction of upstream pipelines in the “Slavneft-Megionneftegaz” oilfield (2012);

– “Rules of technical inspection of upstream pipelines in “Slavneft-Megionneftegaz” (2012);

– “Rules of displacing the crude oil and abandoning the linear segment of upstream pipelines in “Slavneft-Megionneftegaz” (2012);

– “Rules of cleaning the “Orenburgneft” crude oil upstream pipelines from internal deposits” (2013).

We possess more than 15 years of experience in engineering standard-technical documents, as well as technology regulations of operating O&G facilities.

## JUSTIFICATION OF HAZARDOUS PRODUCTION FACILITY SAFETY

Justification of hazardous production facility safety is a document, containing information on the results of assessing the risks of accidents on-site the hazardous production facility (HPF) and the accident threat, as well as conditions of HPF safe operation, requirements for its maintenance and abandonment. Justification of HPF safety is necessary in case of waiver of industrial safety requirements, set by federal norms and regulations, as well as in case of lack of existing norms and regulations. The necessity of HPF safety justification is set by item 4 of article 3 in Federal Law-116. The developed justification of HPF safety is subject to mandatory industrial safety examination. We have developed safety justifications for 5 HPFs of “Orenburgneft”.

## EXAMINATION OF PIPELINE INDUSTRIAL SAFETY

Examination of HPF industrial safety is conducted in accordance with the rules of conducting the examination for specific facilities, based on the data of inspected facility and calculation of the facility residue life. We possess the license № DE-00-013475 for examining the HPF industrial safety.

## DISPLACEMENT OF THE PRODUCT FROM DECOMMISSIONED PIPELINES

### Work stages:

**1 stage** – assemble temporary cleaning pig launcher and catcher stations (if necessary);

**2 stage** – depending on the type of product in the pipeline chose the cleaning pig for displacing the product, as well as the devices for tracking and monitoring the cleaning pig's progression along the pipeline;

**3 stage** – prepare and treat-iron the technical facilities (compressor, pump) for propulsion of the cleaning pipe along the pipeline, selection of check points for monitoring the cleaning pig's running;

**4 stage** – kick the cleaning pig into the launcher station and launch into the pipe, control its departure from the launcher station;

**5 stage** – track the run of a cleaning pig in the pipeline at the check points;

**6 stage** – receive the cleaning pig at the catcher station, identify its location in the station, retrieve the cleaning pig from the catcher station.

## ELABORATION OF QUALIFYING TESTS FOR THE PERSONNEL OF O&G COMPANIES

Qualifying test for "KazTransOil" personnel are elaborated in 2000.

The test are compiled, upon analyzing the field of activities of the company's key technical departments, in terms of correlation between the degree of industrial safety onsite the O&G facilities and proficiency of the managers and technical engineering personnel, as well as modern technological directions and methods of midstream operations.

Each questionnaire reflects various topics on occupational proficiency, legislative framework of labor relations, contractual commitments and HSSE.

WE POSSESS MORE THAN 20 YEARS OF EXPERIENCE  
IN PIGGING THE PIPELINES.

## GOST-R CERTIFICATES



## LICENSES AND CERTIFICATES OF APPROVAL





# PATENTS ON OUR ENGINEERING



THE COMPANY'S ASSOCIATES HAVE RECEIVED OVER 30 RF PATENTS AND USSR IN-VENTOR'S CERTIFICATES, WHICH ARE IMPLEMENTED WHILE ENGINEERING THE TECHNOLOGIES AND DEVICES FOR CLEANING AND INSPECTING THE PIPELINES.

# DIPLOMAS AND CERTIFICATES





AWARDS



These are the diplomas and certificates awarded to our associates for their participation in various expos and awards. The certificates acknowledge getting additional education.

# VOSTOKNEFTEGAZ

[www.vostokoil.ru](http://www.vostokoil.ru)

Technologies and technical facilities (excluding in-line flaw-detecting devices)  
are designed by the associates of the Limited Liability Company  
“Scientific-technical firm “VOSTOKneftegaz”

General Manager

**Mugallimov Fanzil**

Doctor of Engineering Sciences,  
Honoured inventor of Bashkortostan republic,  
Acad. Gubkin award laureate,  
All-Russian “Engineer of the Year-2008” award laureate  
Tel.: (347)246-49-88, ext.20  
e-mail: [mugallimov@mail.ru](mailto:mugallimov@mail.ru)

Chief engineer

**Mugallimov Azat**

Tel.: +7-917-42-93-133  
E-mail: [VNGAzat@mail.ru](mailto:VNGAzat@mail.ru)

Head of standard-technical documents development department

**Bitueva Regina**

Tel.: (347) 246-49-88, ext. 23  
E-mail: [Vostok-neftegaz@vostokoil.ru](mailto:Vostok-neftegaz@vostokoil.ru)

Chief designer

**Safonov Valentin**

Tel.: (347) 246-49-88, ext. 28  
E-mail: [info@vostokoil.ru](mailto:info@vostokoil.ru)

Head of electronics and software development department

**Pavlov Oleg**

Tel.: (347) 246-49-88, ext. 29  
E-mail: [oleg@vostokoil.ru](mailto:oleg@vostokoil.ru)

Head of sales and marketing department

**Saitova Regina**

Tel.: (347) 246-49-88, ext. 26  
E-mail: [zayavka@vostokoil.ru](mailto:zayavka@vostokoil.ru)

Tel.: (347) 293-34-53, 246-49-88

Fax: (347)246-49-89

E-mail: [info@vostokoil.ru](mailto:info@vostokoil.ru)

E-mail for inquiries: [zayavka@vostokoil.ru](mailto:zayavka@vostokoil.ru)

Mailing address: 450027, Russian Federation,  
Bashkortostan republic, Ufa-27, p/o 11

[www.vostokoil.ru](http://www.vostokoil.ru)

# VOSTOKNEFTEGAZ